



polycon
surface water drainage

LITE Prem 500
DATASHEET

Service . Range . Knowledge

LITE Prem 500

The Lite Prem 500 is a lightweight, flexible, and durable drainage system designed for A15 load capacity. For added strength and durability, an optional attachable edge rail can be included, offering greater adaptability to suit various needs.



Lite Prem 500 - Diagram

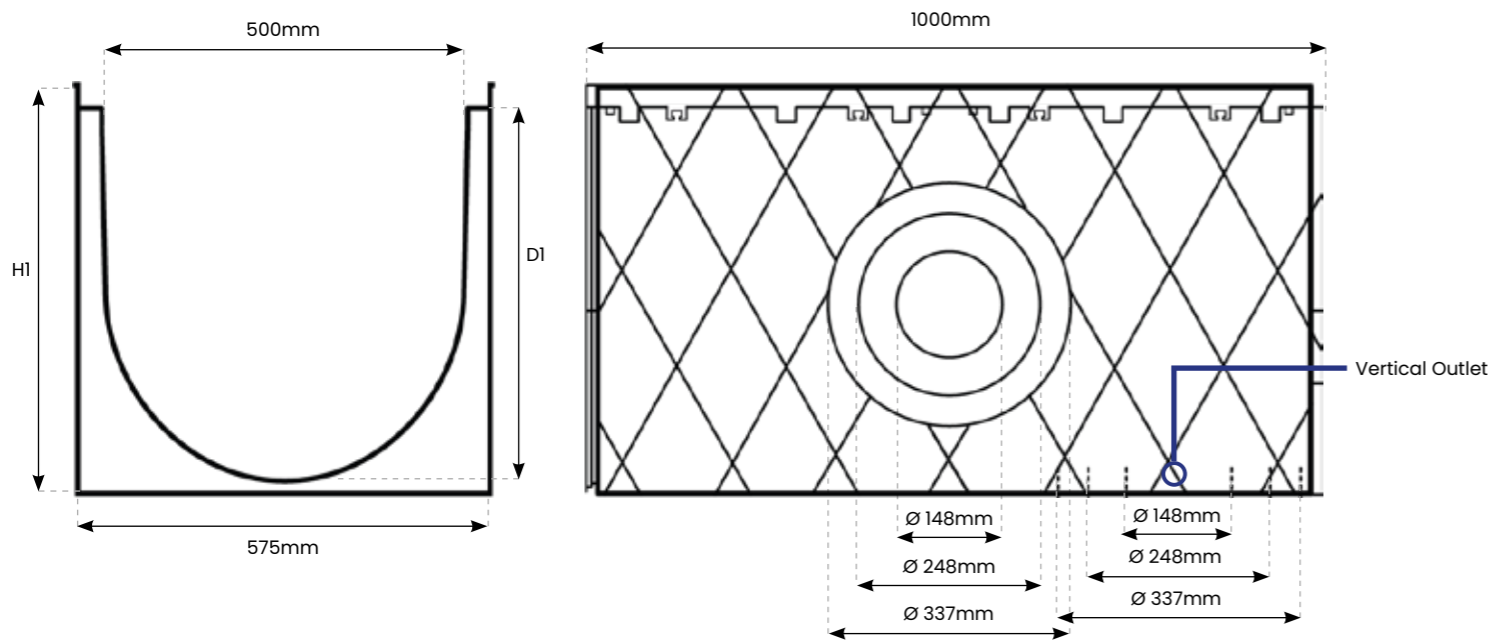

Lite Prem 500 - Specifications

Reference	Description	Overall Depth (H1)	Internal Depth (D1)	Overall Width	Internal Width	Length	Vertical Outlet	Load Class
LP.500.CSB	Lite Prem 500 Composite Slotted Black Grating	550mm	520mm	575mm	500mm	1000mm	148/248/337mm	A15
LP.500.CSB.ER	Lite Prem 500 + Edge Rail Composite Slotted Black Grating	550mm	520mm	580mm	500mm	1000mm	148/248/337mm	A15

DATA SHEET

Gratings



Composite Slotted Black (A15)



Composite Slotted Black + Stainless Steel Edge Rail (A15)

* The Lite Prem channel, without the edge rail, supports load classes from A15 to C250, depending on the grating used.
 ** The channel itself can handle up to F900, but to achieve any load class from C250 to F900, the channel must be equipped with the optional edge rail for enhanced performance and strength.

Accessories



Stainless Steel Edge Rail



Bolt & Bar



Side Clamp

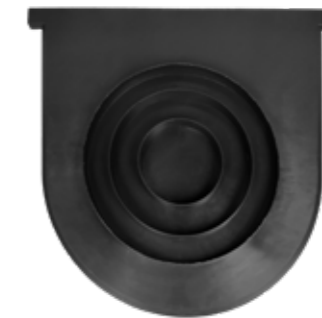

End Cap Outlet

Accessories - Specifications

Reference	Description	Height	Overall Width	Length	Outlet
ECO.LP.500	Lite Prem 500 End Cap Outlet	545mm	575mm	35mm	148/248/337mm
LP.500.CSBG	Lite Prem 500 Composite Slotted Black Grating	28mm	550mm	500mm	-



Polycon Surface Water Drainage

**Widnes Business Park
Foundry Lane
Widnes
Cheshire
WA8 8UB**

**www.polycon.co.uk
0151 422 9747
sales@polycon.co.uk**

Service . Range . Knowledge