

A large truck with blue wheels is shown from a low angle, driving on a dark, textured drainage grate. The truck's tires are prominent, and the blue color of the wheels is a key visual element. The background is a mix of dark blue and white geometric shapes.

**polycon**  
surface water drainage

**SF RANGE**

*Service . Range . Knowledge*

## Welcome To Polycon

Polycon is identified as one of the leading manufacturers, distributors, and suppliers of channel drainage in the UK. We focus on creating a diverse range of water solutions, in various materials, including composite, polymer concrete, SMC, and steel.

Polycon's unique look at the market and expert knowledge of the industry ensures we can supply a wide range of high-quality products suitable for any application. This includes building drainage, landscaping, sports facilities, distribution centres, highways, and airports.

Our design team provides innovative and efficient hydraulic solutions to ensure we can offer your drainage needs the best product/solution. We have a vast and experienced overview of our working industry and have been manufacturing, distributing, and selling channel drainage for over 8 years. We thrive on acting upon your feedback to improve and develop our products to fit flawlessly with the constantly changing market and demand from our customers.

---

At Polycon we focus our attention on professionals who sit within the construction industry, targeting our products to specifiers, architects, engineers, and contractors. Therefore, we understand the importance of expanding our product portfolio to create the most efficient surface water drainage systems.

We are a dynamic and evolving company with a focus on quality, innovation, and service. As a result, you can rely on us to handle your project needs in every way to the best of our ability.

## Contents

<i>SF 100</i>	<i>3</i>
<i>SF 150</i>	<i>13</i>
<i>SF 200</i>	<i>23</i>
<i>SF 300</i>	<i>33</i>
<i>Installation</i>	<i>41</i>

**Service • Range • Knowledge**

# SF100

## SF 100

Polycon's SF 100 drainage channels are a top-notch solution for efficient water management in various settings. These channels are renowned for their quality and advanced features, making them an excellent choice for drainage needs. Here, we'll highlight the main advantages of the SF 100 drainage channels supplied by Polycon.

One of the standout features of Polycon's SF 100 channels is their innovative UniLink Joint System. This system ensures a seamless and secure connection between channel sections, eliminating weak points and preventing leaks. It simplifies installation and enhances the overall durability of the drainage system.

The SF 100 channels come equipped with a Rapid Lock Fastening system, simplifying the installation process. This feature saves time and reduces labour costs, making it a cost-effective choice for various projects.

SF 100 drainage channels are designed to withstand heavy loads and harsh conditions. Their heavy-duty construction makes them suitable for areas with high traffic, such as industrial facilities, parking lots, and commercial sites. These channels can effectively handle the demands of even the most challenging environments.

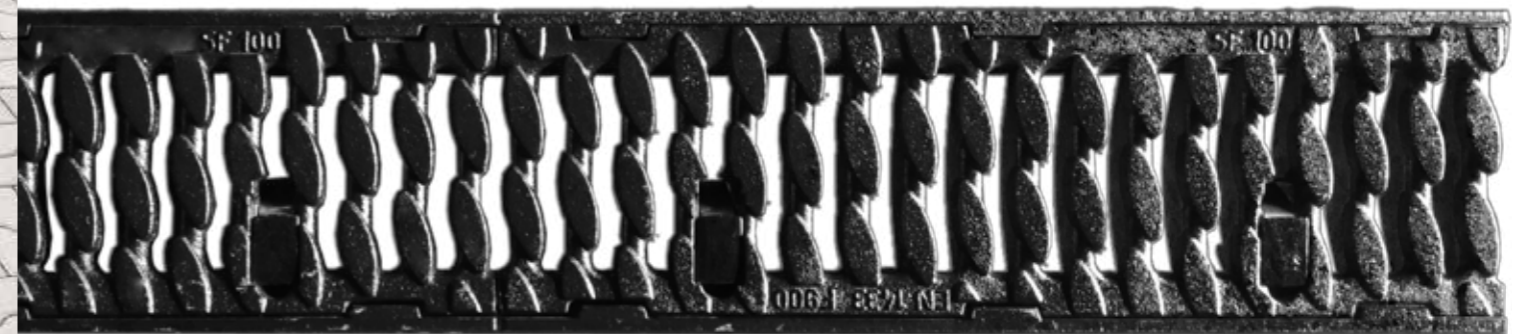

### Load Class

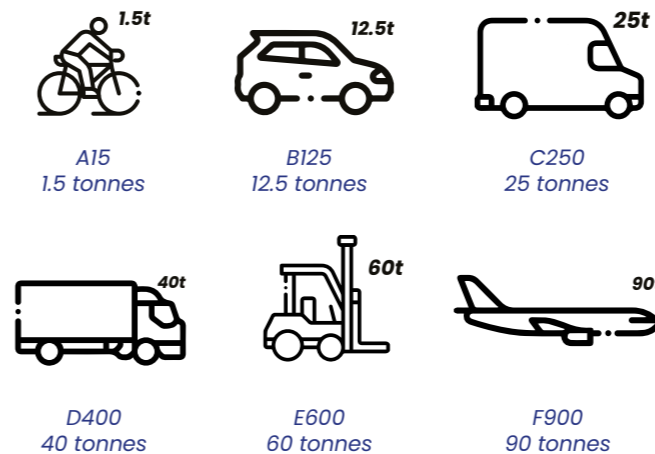

### Applications

- Civil yards
- Warehouses
- Farms
- Docks
- Loading yards
- Commercial airport
- Flight operation areas

# SF 100 – Overview

## Colour Options



### Ductile Iron Edge Rail

To enhance the channels' durability and load-bearing capacity, they feature a ductile iron edge. Ductile iron is recognized for its exceptional strength and impact resistance, which extends the lifespan of the drainage channels and ensures reliability in high-stress areas.

### Material

The SF 100 channels are constructed from polymer concrete, a material known for its exceptional strength and durability. This choice of material ensures longevity and resistance to corrosion, making them ideal for long-term use in drainage applications.



### Bottom Outlet

The bottom outlet in the base of the channel allows for downward drainage into a 110mm sewer connection.

## Load Classes

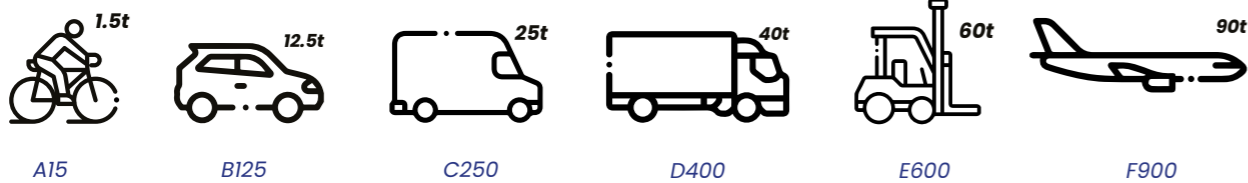

## Depth Options

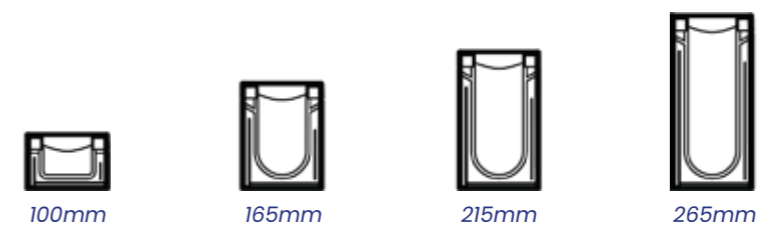

# SF 100

The KE 100 channel's combination of a galvanised or stainless-steel edge rail and a polymer concrete core results in a robust and long-lasting drainage solution. Its superior durability, resistance to corrosion, and ease of installation make it a preferred choice for a wide range of construction and civil engineering projects, ensuring effective and sustainable water management.

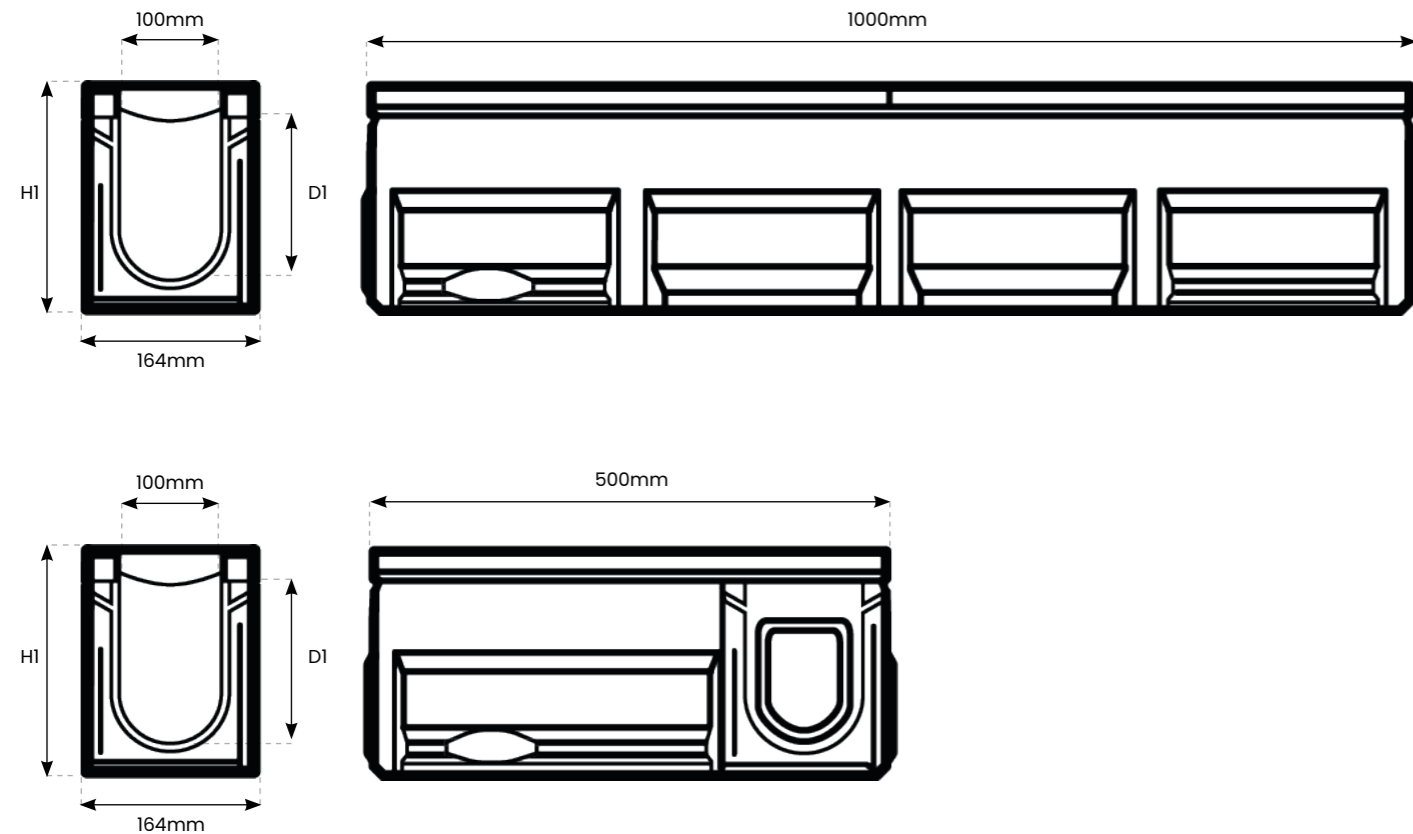

## Channel Properties

Polymere concrete:	Polyester resin-based with mineral aggregates, additives.
Compressive strength:	> 90 N/mm <sup>2</sup>
Bending tensile strength:	> 22 N/mm <sup>2</sup>
Modulus of elasticity:	ca. 25 kN/mm <sup>2</sup>
Density:	2.1 - 2.3 g/dm <sup>3</sup>
Heat resistance:	100°C (permenant loading)
Frost resistance:	-50°C
Water penetration depth:	0mm

# Channel Types

Reference	Description	Slope	Length	Overall Width	Internal Width	Overall Depth(HI)	Internal Depth(DI)	Weight
SF.100.0	SF - 100 Channel No. 0*	0%	1000mm	164mm	100mm	165mm	145mm	36kg
SF.100.0R	SF- 100 Channel No. 0R***	0%	1000mm	164mm	100mm	165mm	145mm	36kg
SF.100.005	SF - 100 Channel No. 005**/*	0%	500mm	164mm	100mm	165mm	145mm	19kg
SF.100.1	SF - 100 Channel No. 1	0.5%	1000mm	164mm	100mm	170mm	150mm	36kg
SF.100.2	SF - 100 Channel No. 2	0.5%	1000mm	164mm	100mm	175mm	155mm	36.4kg
SF.100.3	SF - 100 Channel No. 3	0.5%	1000mm	164mm	100mm	180mm	160mm	36.6kg
SF.100.4	SF - 100 Channel No. 4	0.5%	1000mm	164mm	100mm	185mm	165mm	36.8kg
SF.100.5	SF - 100 Channel No. 5	0.5%	1000mm	164mm	100mm	190mm	170mm	37kg
SF.100.6	SF - 100 Channel No. 6	0.5%	1000mm	164mm	100mm	195mm	175mm	37.3kg
SF.100.7	SF - 100 Channel No. 7	0.5%	1000mm	164mm	100mm	200mm	180mm	37.5kg
SF.100.8	SF - 100 Channel No. 8	0.5%	1000mm	164mm	100mm	205mm	185mm	38kg
SF.100.9	SF - 100 Channel No. 9	0.5%	1000mm	164mm	100mm	210mm	190mm	38.3kg
SF.100.10	SF - 100 Channel No. 10*	0.5%	1000mm	164mm	100mm	215mm	195mm	38.5kg
SF.100.010	SF - 100 Channel No. 010*	0%	1000mm	164mm	100mm	215mm	195mm	38.5kg
SF.100.010R	SF - 100 Channel No. 010R*	0%	1000mm	164mm	100mm	215mm	195mm	38.5kg
SF.100.0105	SF - 100 Channel No. 0105**/*	0%	500mm	164mm	100mm	215mm	195mm	21kg
SF.100.11	SF - 100 Channel No. 11	0.5%	1000mm	164mm	100mm	220mm	200mm	39kg
SF.100.12	SF - 100 Channel No. 12	0.5%	1000mm	164mm	100mm	225mm	205mm	39.3kg
SF.100.13	SF- 100 Channel No. 13	0.5%	1000mm	164mm	100mm	230mm	210mm	39.8kg
SF.100.14	SF - 100 Channel No. 14	0.5%	1000mm	164mm	100mm	235mm	215mm	40.5kg
SF.100.15	SF - 100 Channel No. 15*	0.5%	1000mm	164mm	100mm	240mm	220mm	41kg
SF.100.16	SF - 100 Channel No. 16	0.5%	1000mm	164mm	100mm	245mm	225mm	41.4kg
SF.100.17	SF - 100 Channel No. 17	0.5%	1000mm	164mm	100mm	250mm	230mm	41.6kg
SF.100.18	SF - 100 Channel No. 18	0.5%	1000mm	164mm	100mm	255mm	235mm	41.7kg
SF.100.19	SF - 100 Channel No. 19	0.5%	1000mm	164mm	100mm	260mm	240mm	41.9kg
SF.100.20	SF - 100 Channel No. 20*	0.5%	1000mm	164mm	100mm	265mm	245mm	42kg
SF.100.020	SF - 100 Channel No. 020*	0%	1000mm	164mm	100mm	265mm	245mm	42kg
SF.100.020R	SF- 100 Channel No. 020R***	0%	1000mm	164mm	100mm	265mm	245mm	42kg
SF.100.0205	SF - 100 Channel No. 0205**/*	0%	500mm	164mm	100mm	265mm	245mm	23kg
SF.100.0100P	SF - 100 Channel No. 100-P*	0%	1000mm	164mm	100mm	100mm	80mm	32kg
SF.100.0100PR	SF - 100 Channel No. 100-PR***	0%	1000mm	164mm	100mm	100mm	80mm	32kg

\* Channel with mouldings for vertical outlet DA/OD 110.

\*\* Channel with sidewise perforations for the connection of t-junctions, elbow joints and cross- over joints and vertical outlet.

\*\*\* Channel with vertical pipe socket DA/OD 110.

# Accessories

## Sump Unit

Sump Units act as a reservoir, temporarily storing excess water before discharging it in a controlled manner to prevent adverse effects of water accumulation. The Sump Unit is excellent for collecting debris and waste that can get into the system. It comes with a silt bucket inside for easy cleaning.



Sump Unit

## End Cap

End Caps can be used at the end of your channel run to stop the flow of water.



End Cap

## End Cap Outlet

The End Cap Outlet can be used at the end of the run to allow water to be taken to your exterior drainage pipes and away from the channel.



End Cap Outlet

## Pipe Socket

The Pipe Socket facilitates the seamless integration of drainage channels with the underground pipe network, ensuring effective water management and preventing waterlogging or surface flooding. It essentially acts as the link between the surface drainage system and the underground drainage infrastructure.



Pipe Socket

## Accessories- Specifications

Reference	Description	Length	Height (H)	Overall Width	Weight (KG)	Outlet
SF.100.SU	SF 100 Sump Unit	500mm	585mm	164mm	42kg	110mm
SF.100.EC	SF 100 End Cap No. 0 - 20	20mm	165-265mm	164mm	2.4kg	-
SF.100.ECO	SF 100 End Cap Outlet No. 0 - 20	30mm	165mm	164mm	2.5kg	110mm
SF.100.PS.160	SF 100 Pipe Socket 160mm	160mm	-	160mm	0.2kg	-
SF.100.PS.200	SF 100 Pipe Socket 200mm	200mm	-	200mm	0.6kg	-

# Grating



Ductile Iron Oval Grating (F900)

## Grating Properties

Type:	OvalGrip slotted cast iron grating
Material:	EN-GJS cast iron
Length:	500mm
Inlet cross-section:	490 cm <sup>2</sup> /m, 680cm <sup>2</sup> /m, 916cm <sup>2</sup> /m, 1196 cm <sup>2</sup> /m
Fastening:	GJS Cast edge rail

# Sloped, Stepped, Level

There are 3 different scenarios in which the SF 100 drainage channel can be installed. However, the purpose of all 3 of these variations is to provide a pathway for the removal of unwanted surface water in a selected area. The specifics of which channel should be used are dependent on multiple factors such as the terrain, flow rate, and other environmental conditions.

## Sloped Invert

A channel run with a sloped invert has a consistent downward gradient along its length. The slope is designed to provide a continuous downward flow of water, allowing gravity to assist in the drainage of water. When using a sloped channel it is carefully calculated to ensure that the water will flow at an appropriate velocity to prevent sedimentation or excessive erosion.

## Sloped Invert

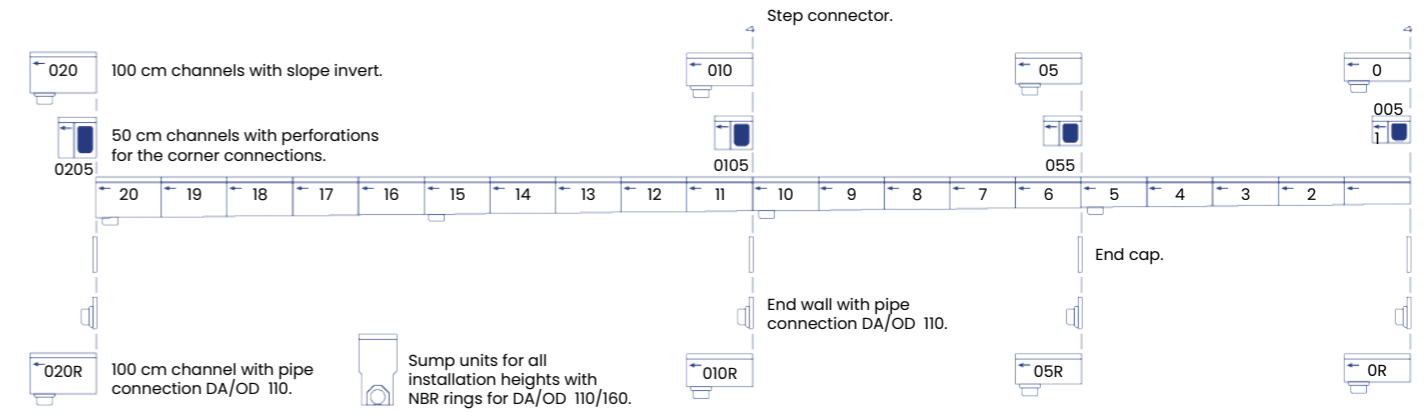

## Stepped Invert

Stepped drainage channels are designed with a series of steps or drops along the run of the channel. These steps create a cascading effect, which helps to control the velocity of the water and prevent erosion.

## Stepped Invert

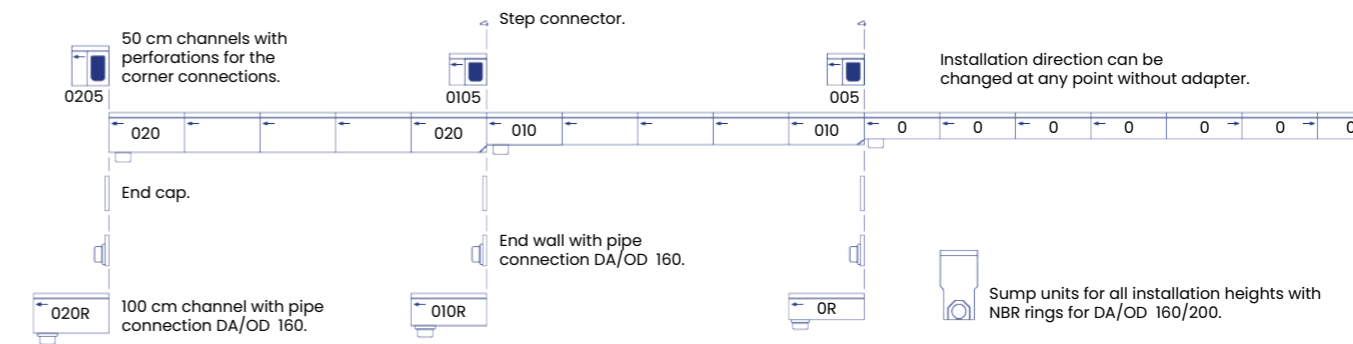

## Level Invert

Level inverts are usually used in areas with relatively low slopes or insignificant water rates. They allow water to flow smoothly and evenly without the need for any significant changes in elevation. Channels with a level invert are often used in urban areas, where the goal is to transport water efficiently and prevent flooding.

## Level Invert

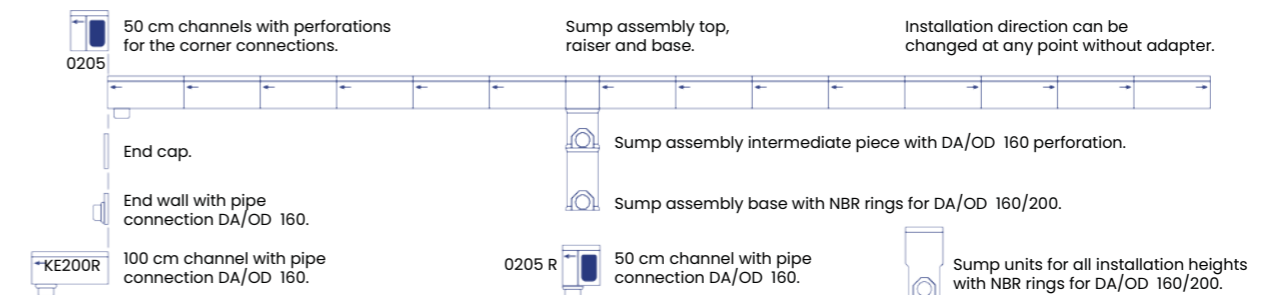

# SF 150

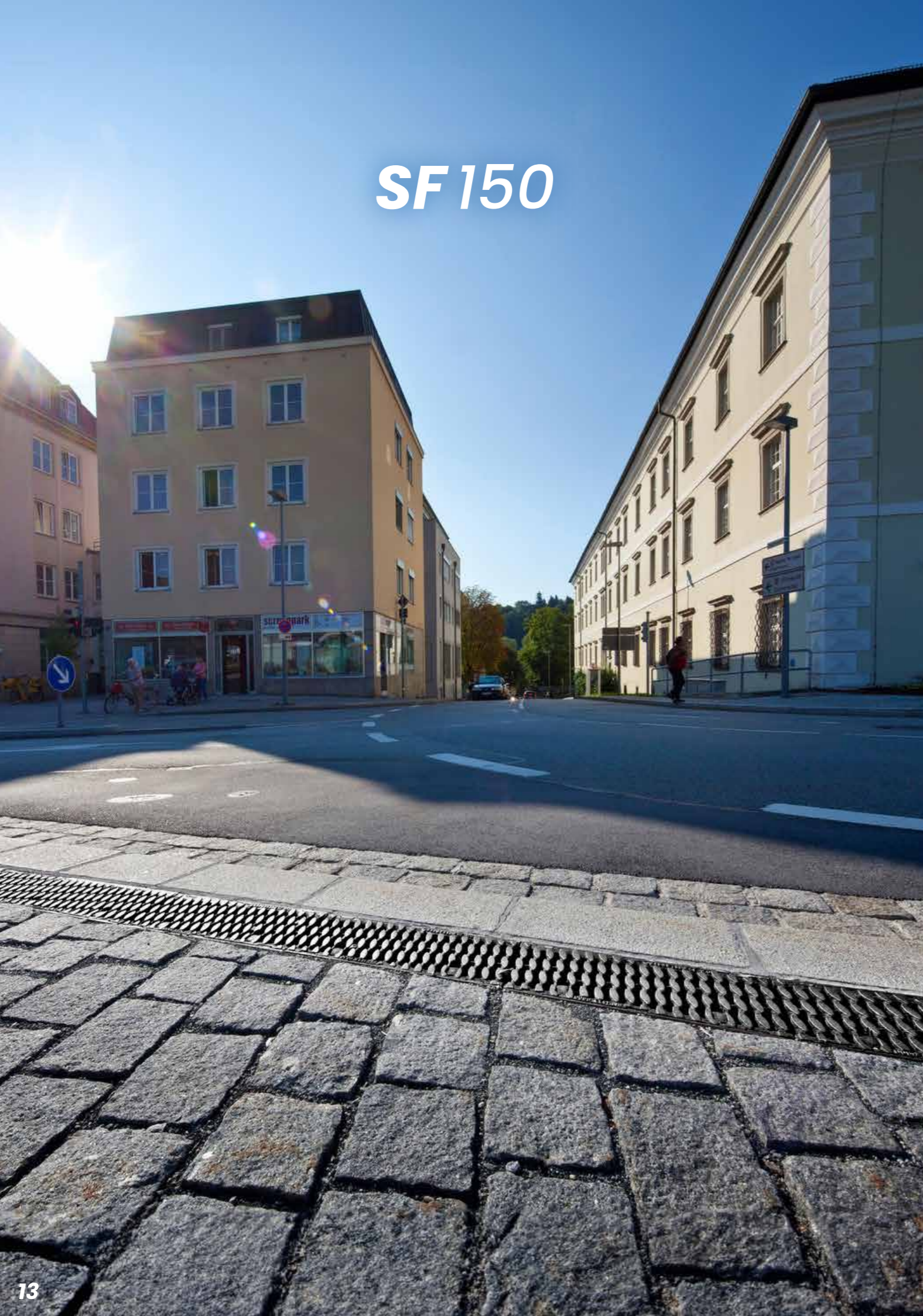

## SF 150

Polycon's SF 150 drainage channels are a top-notch solution for efficient water management in various settings. These channels are renowned for their quality and advanced features, making them an excellent choice for drainage needs. Here, we'll highlight the main advantages of the SF 150 drainage channels supplied by Polycon.

One of the standout features of Polycon's SF 150 channels is their innovative UniLink Joint System. This system ensures a seamless and secure connection between channel sections, eliminating weak points and preventing leaks. It simplifies installation and enhances the overall durability of the drainage system.

The SF 150 channels come equipped with a Rapid Lock Fastening system, simplifying the installation process. This feature saves time and reduces labour costs, making it a cost-effective choice for various projects.

SF 150 drainage channels are designed to withstand heavy loads and harsh conditions. Their heavy-duty construction makes them suitable for areas with high traffic, such as industrial facilities, parking lots, and commercial sites. These channels can effectively handle the demands of even the most challenging environments.

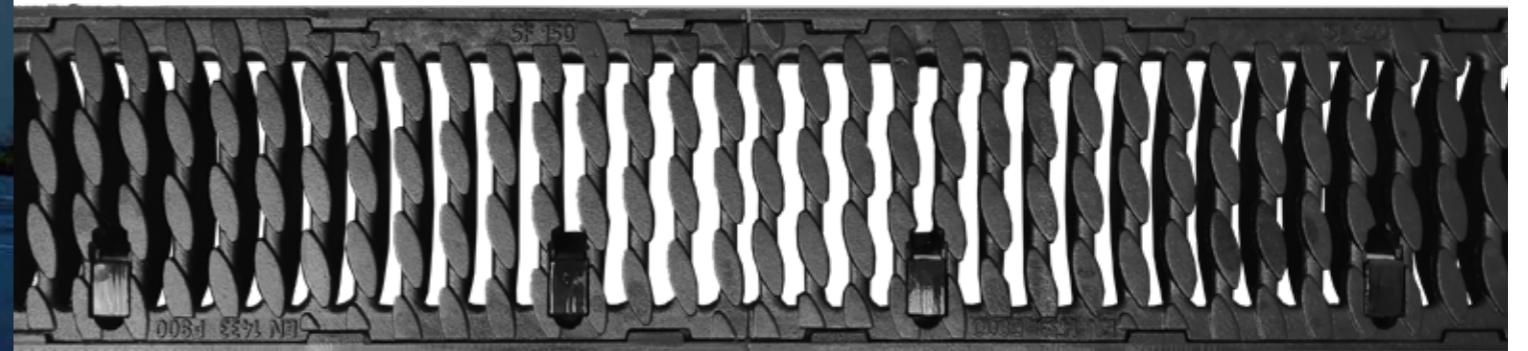

### Load Class



1.5t

A15  
1.5 tonnes



12.5t

B125  
12.5 tonnes

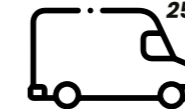

25t

C250  
25 tonnes



40t

D400  
40 tonnes

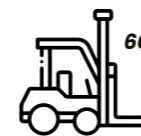

60t

E600  
60 tonnes



90t

F900  
90 tonnes

### Applications

- Civil yards
- Warehouses
- Farms
- Docks
- Loading yards
- Commercial airport
- Flight operation areas

# SF 150 - Overview

## Colour Options

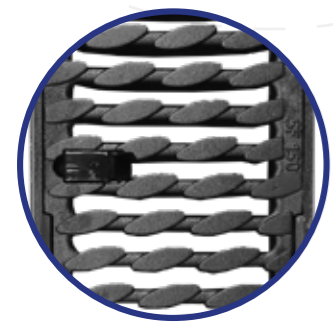

**Grating**  
4 - point locking. 90 tonne loading.

**Material**  
The SF 150 channels are constructed from polymer concrete, a material known for its exceptional strength and durability. This choice of material ensures longevity and resistance to corrosion, making them ideal for long-term use in drainage applications.

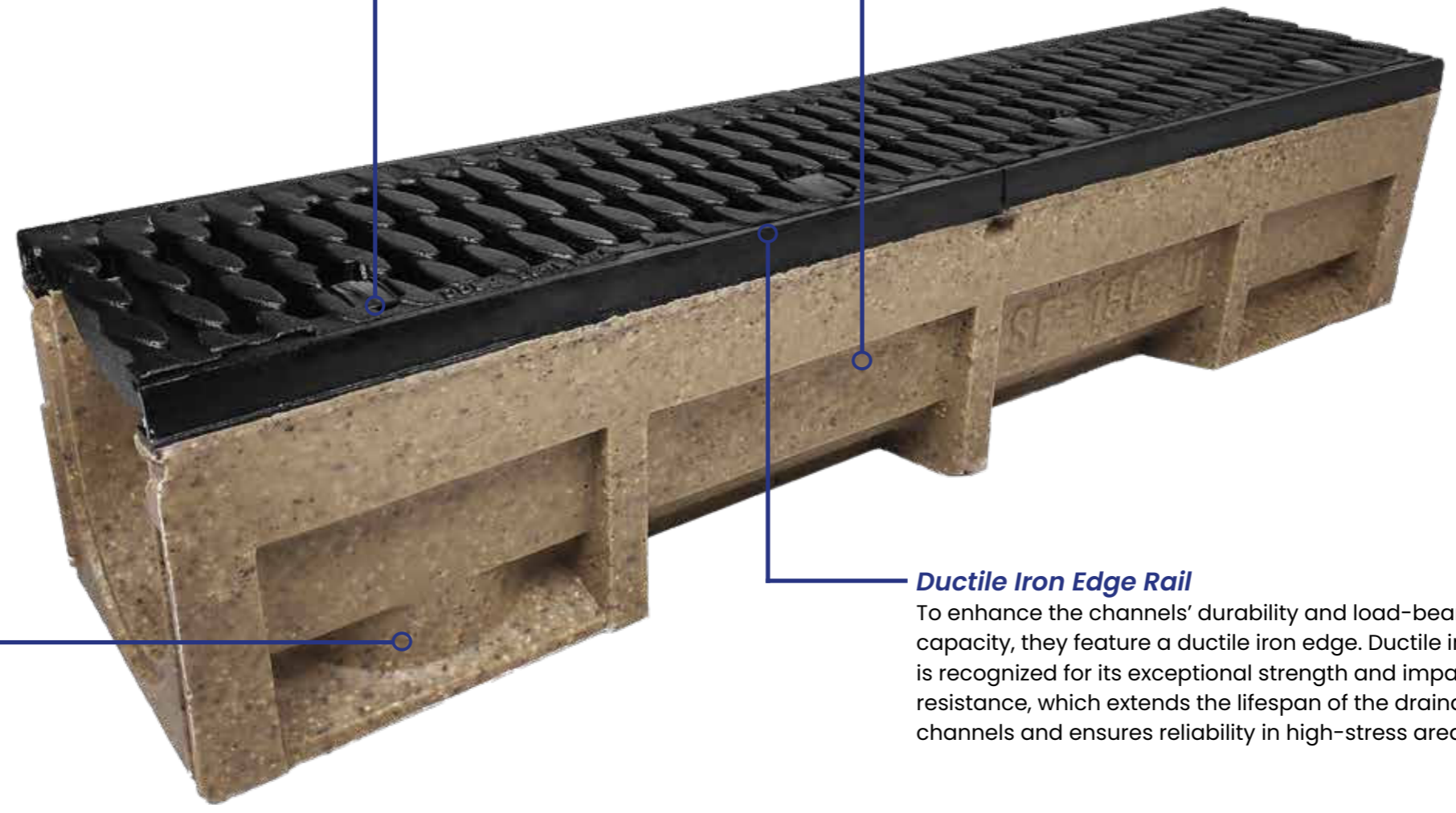

**Bottom Outlet**  
The bottom outlet in the base of the channel allows for downward drainage into a 110mm sewer connection.

**Ductile Iron Edge Rail**  
To enhance the channels' durability and load-bearing capacity, they feature a ductile iron edge. Ductile iron is recognized for its exceptional strength and impact resistance, which extends the lifespan of the drainage channels and ensures reliability in high-stress areas.

## Load Classes

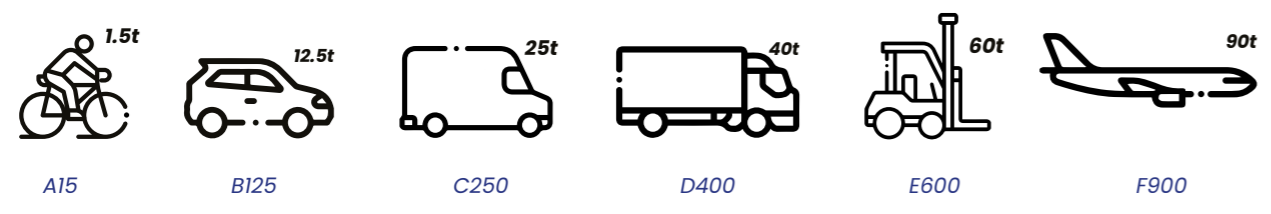

## Depth Options

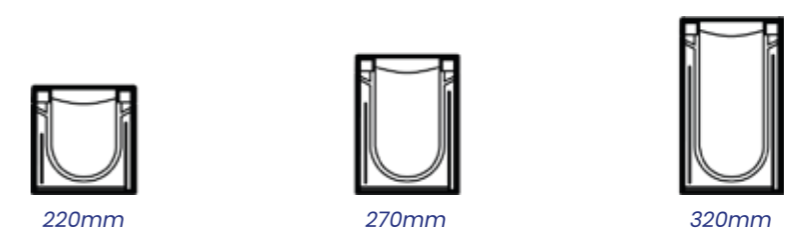

# SF 150

Polycon's SF 150 drainage channels offer a comprehensive solution for effective water management. With their Unilink Joint System, heavy-duty design, polymer concrete construction, ductile iron edge, and rapid lock fastening, they provide a durable, versatile, and efficient solution for draining water and managing surface runoff in demanding environments. These channels are ideal for areas where strength, longevity, and ease of installation are paramount.

1000mm Channel Diagram

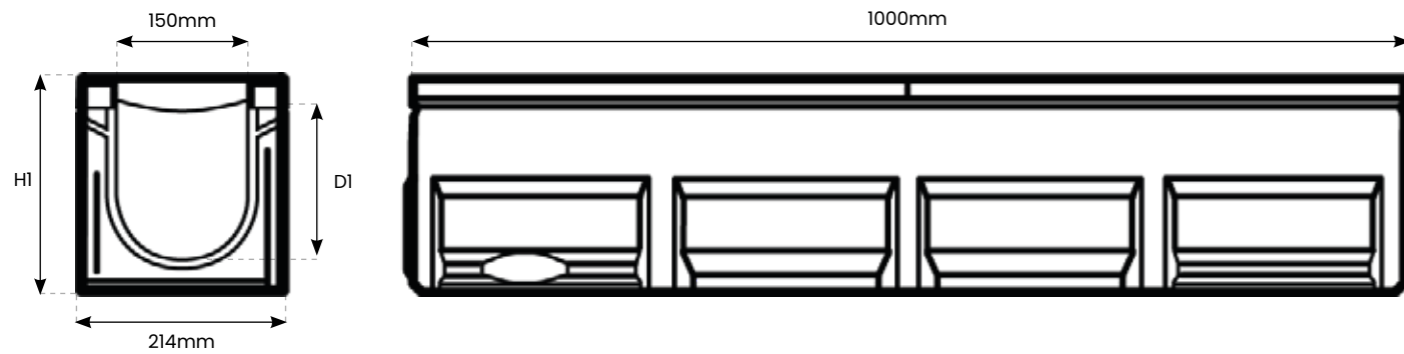

500mm Channel Diagram

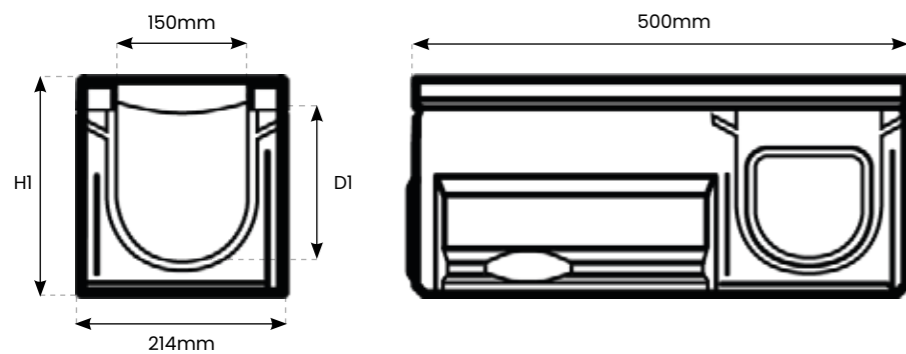

## Channel Properties

<b>Polymere concrete:</b>	<b>Polyester resin-based with mineral aggregates, additives.</b>
<b>Compressive strength:</b>	<b>&gt; 90 N/mm<sup>2</sup></b>
<b>Bending tensile strength:</b>	<b>&gt; 22 N/mm<sup>2</sup></b>
<b>Modulus of elasticity:</b>	<b>ca. 25 kN/mm<sup>2</sup></b>
<b>Density:</b>	<b>2.1 - 2.3 g/cm<sup>3</sup></b>
<b>Water penetration depth:</b>	<b>0 mm</b>
<b>Heat resistance:</b>	<b>100°C</b>
<b>Frost resistance:</b>	<b>-50°C</b>
<b>Water absorbtion:</b>	<b>0.05 %</b>

## Channel Types

Reference	Description	Slope	Length	Overall Width	Internal Width	Overall Depth(HI)	Internal Depth(DI)	Weight
SF.150.0	SF - 150 Channel No. 0*	0%	1000mm	214mm	150mm	220mm	200mm	30kg
SF.150.0R	SF - 150 Channel No. 0R***	0%	1000mm	214mm	150mm	220mm	200mm	30kg
SF.150.005	SF - 150 Channel No. 005**/*	0%	500mm	214mm	150mm	220mm	200mm	17kg
SF.150.1	SF - 150 Channel No. 1*	0.5%	1000mm	214mm	150mm	225mm	205mm	33.4kg
SF.150.2	SF - 150 Channel No. 2*	0.5%	1000mm	214mm	150mm	230mm	210mm	33.8kg
SF.150.3	SF - 150 Channel No. 3*	0.5%	1000mm	214mm	150mm	235mm	215mm	34.2kg
SF.150.4	SF - 150 Channel No. 4*	0.5%	1000mm	214mm	150mm	240mm	220mm	34.6kg
SF.150.5	SF - 150 Channel No. 5*	0.5%	1000mm	214mm	150mm	245mm	225mm	35kg
SF.150.6	SF - 150 Channel No. 6*	0.5%	1000mm	214mm	150mm	250mm	230mm	35.4kg
SF.150.7	SF - 150 Channel No. 7*	0.5%	1000mm	214mm	150mm	255mm	235mm	35.8kg
SF.150.8	SF - 150 Channel No. 8*	0.5%	1000mm	214mm	150mm	260mm	240mm	36.2kg
SF.150.9	SF - 150 Channel No. 9*	0.5%	1000mm	214mm	150mm	265mm	245mm	36.6kg
SF.150.10	SF - 150 Channel No. 10*	0.5%	1000mm	214mm	150mm	270mm	250mm	37kg
SF.150.010	SF - 150 Channel No. 010*	0%	1000mm	214mm	150mm	270mm	250mm	37kg
SF.150.010R	SF - 150 Channel No. 010R*	0%	1000mm	214mm	150mm	270mm	250mm	37kg
SF.150.0105	SF - 150 Channel No. 0105**/*	0%	500mm	214mm	150mm	270mm	250mm	18.8kg

\* Channel with mouldings for vertical outlet DA/OD 160  
 \*\* Channel with sidewise perforations for the connection of t-junctions, elbow joints and cross-over joints  
 \*\*\* Channel with vertical pipe socket DA/OD 160

# Accessories

## Sump Unit

Sump Units act as a reservoir, temporarily storing excess water before discharging it in a controlled manner to prevent adverse effects of water accumulation. The Sump Unit is excellent for collecting debris and waste that can get into the system. It comes with a silt bucket inside for easy cleaning.



Sump Unit

## End Cap

End Caps can be used at the end of your channel run to stop the flow of water.



End Cap

## End Cap Outlet

The End Cap Outlet can be used at the end of the run to allow water to be taken to your exterior drainage pipes and away from the channel.



End Cap Outlet

## Pipe Socket

The Pipe Socket facilitates the seamless integration of drainage channels with the underground pipe network, ensuring effective water management and preventing waterlogging or surface flooding. It essentially acts as the link between the surface drainage system and the underground drainage infrastructure.



Pipe Socket

## Accessories- Specifications

Reference	Description	Length	Height (H)	Overall Width	Weight (KG)	Outlet
SF.150.SU	SF 150 Sump Unit	500mm	620mm	214mm	55.1kg	110mm
SF.150.EC	SF 150 End Cap No. 0 - 20	20mm	165-265mm	214mm	2.5kg	-
SF.150.ECO	SF 150 End Cap Outlet No. 0 - 20	30mm	220mm	214mm	3.4kg	110mm
SF.150.PS.160	SF 150 Pipe Socket 160mm	160mm	-	160mm	0.4kg	-
SF.150.PS.200	SF 150 Pipe Socket 200mm	200mm	-	200mm	0.8kg	-

# Grating



Ductile Iron Oval Grating (F900)

## Grating Properties

Type:	OvalGrip slotted cast iron grating
Material:	EN-GJS cast iron
Length:	500mm
Inlet cross-section:	490 cm <sup>2</sup> /m, 680cm <sup>2</sup> /m, 916cm <sup>2</sup> /m, 1196 cm <sup>2</sup> /m
Fastening:	GJS Cast edge rail

# Sloped, Stepped, Level

There are 3 different scenarios in which the SF 150 drainage channel can be installed. However, the purpose of all 3 of these variations is to provide a pathway for the removal of unwanted surface water in a selected area. The specifics of which channel should be used are dependent on multiple factors such as the terrain, flow rate, and other environmental conditions.

## Sloped Invert

A channel run with a sloped invert has a consistent downward gradient along its length. The slope is designed to provide a continuous downward flow of water, allowing gravity to assist in the drainage of water. When using a sloped channel it is carefully calculated to ensure that the water will flow at an appropriate velocity to prevent sedimentation or excessive erosion.

## Stepped Invert

Stepped drainage channels are designed with a series of steps or drops along the run of the channel. These steps create a cascading effect, which helps to control the velocity of the water and prevent erosion.

## Level Invert

Level inverts are usually used in areas with relatively low slopes or insignificant water rates. They allow water to flow smoothly and evenly without the need for any significant elevation changes. Channels with a level invert are often used in urban areas, where the goal is to transport water efficiently and prevent flooding.

## Sloped Invert

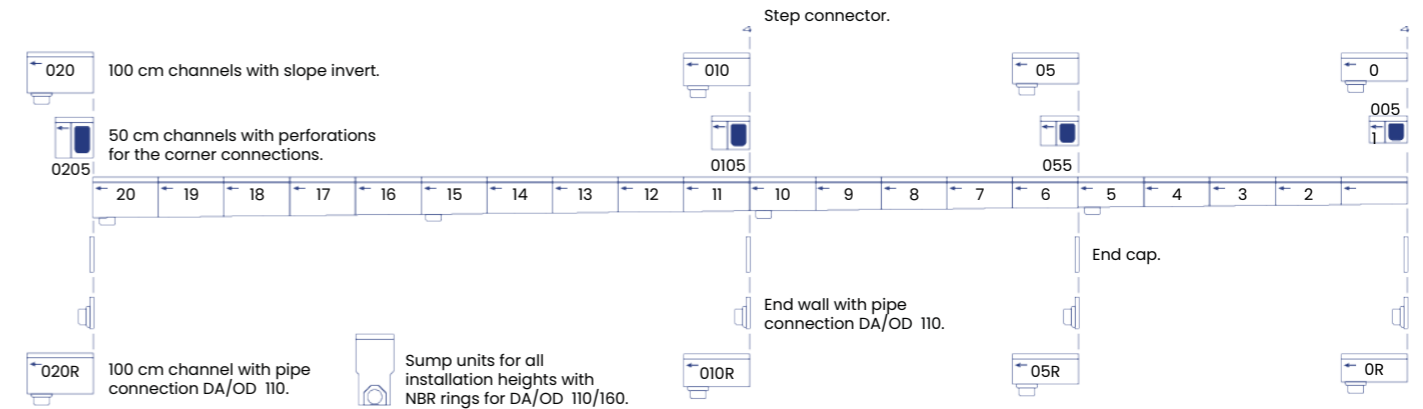

## Stepped Invert

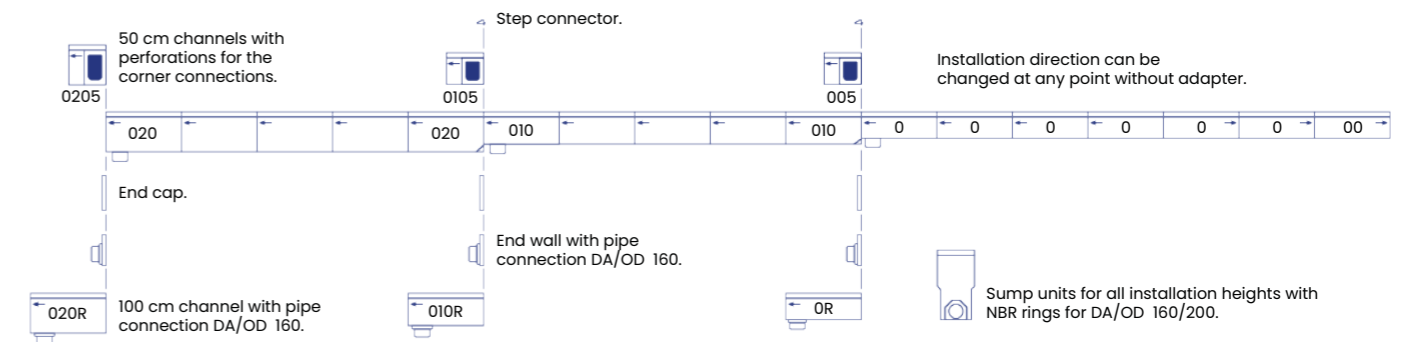

## Level Invert

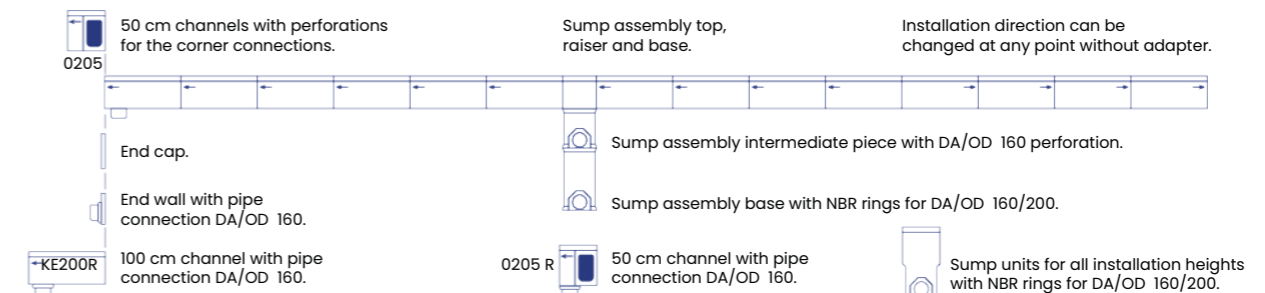

# SF 200

## SF 200

Polycon's SF 200 drainage channels are a top-notch solution for efficient water management in various settings. These channels are renowned for their quality and advanced features, making them an excellent choice for drainage needs. Here, we'll highlight the main advantages of the SF 200 drainage channels supplied by Polycon.

One of the standout features of Polycon's SF 200 channels is their innovative Unilink Joint System. This system ensures a seamless and secure connection between channel sections, eliminating weak points and preventing leaks. It simplifies installation and enhances the overall durability of the drainage system.

The SF 200 channels come equipped with a Rapid Lock Fastening system, simplifying the installation process. This feature saves time and reduces labour costs, making it a cost-effective choice for various projects.

SF 200 drainage channels are designed to withstand heavy loads and harsh conditions. Their heavy-duty construction makes them suitable for areas with high traffic, such as industrial facilities, parking lots, and commercial sites. These channels can effectively handle the demands of even the most challenging environments.

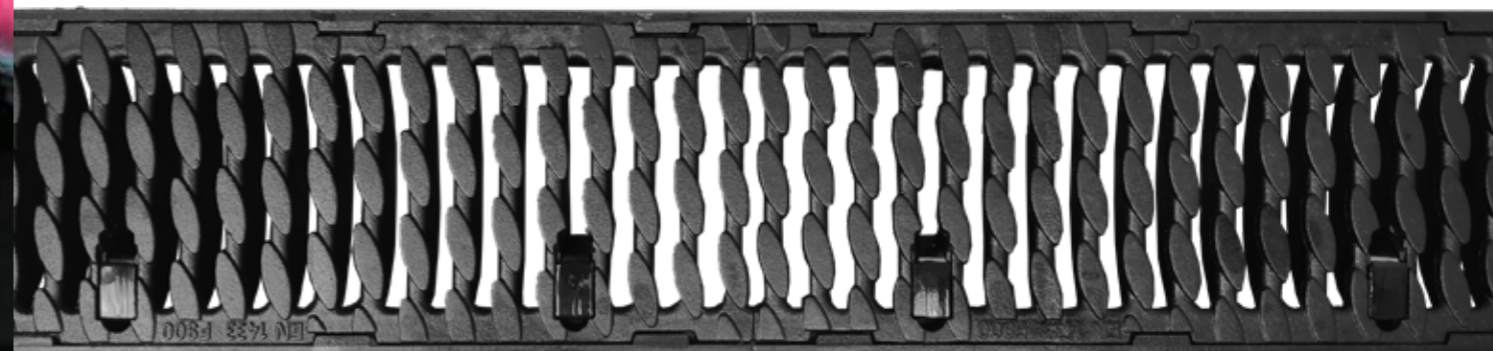

### Load Class



A15  
1.5 tonnes



B125  
12.5 tonnes



C250  
25 tonnes



D400  
40 tonnes

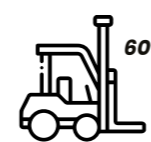

E600  
60 tonnes



F900  
90 tonnes

### Applications

- Civil yards
- Warehouses
- Farms
- Docks
- Loading yards
- Commercial airport
- Flight operation areas

# SF 200 - Overview

## Colour Options

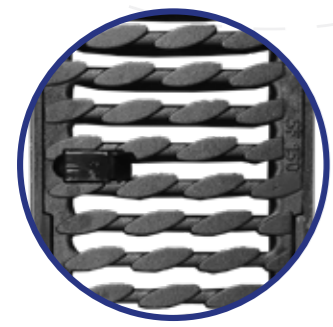

**Grating**  
4 - point locking. 90 tonne loading.

**Material**  
The SF 200 channels are constructed from polymer concrete, a material known for its exceptional strength and durability. This choice of material ensures longevity and resistance to corrosion, making them ideal for long-term use in drainage applications.

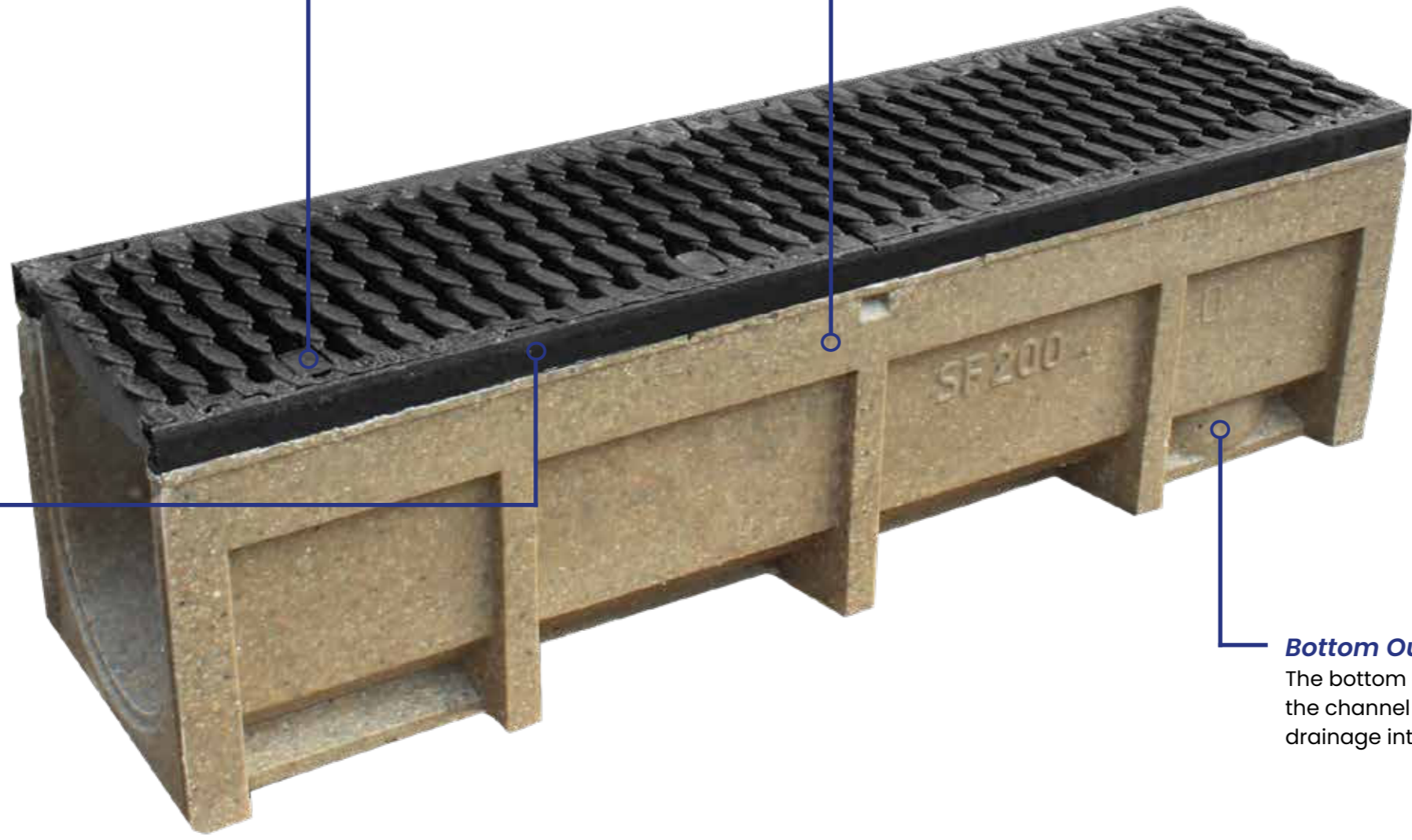

**Ductile Iron Edge Rail**  
To enhance the channels' durability and load-bearing capacity, they feature a ductile iron edge. Ductile iron is recognized for its exceptional strength and impact resistance, which extends the lifespan of the drainage channels and ensures reliability in high-stress areas.

**Bottom Outlet**  
The bottom outlet in the base of the channel allows for downward drainage into a 160mm sewer connection.

## Load Classes

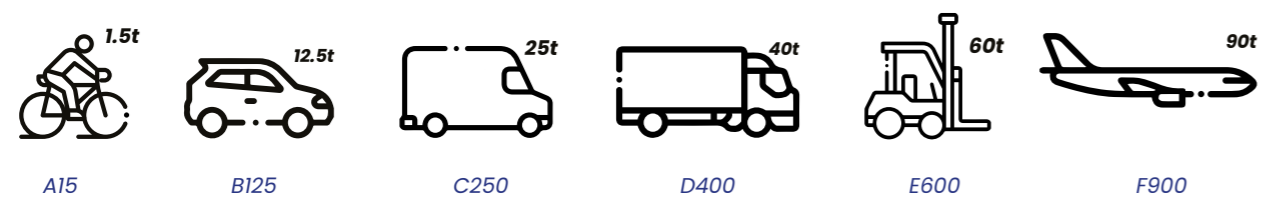

## Depth Options

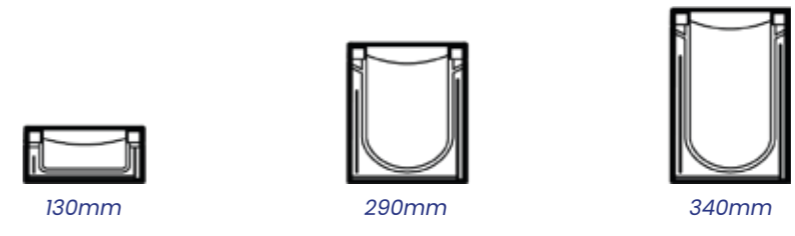

# SF 200

Polycon's SF 200 drainage channels offer a comprehensive solution for effective water management. With their Unilink Joint System, heavy-duty design, polymer concrete construction, ductile iron edge, and rapid lock fastening, they provide a durable, versatile, and efficient solution for draining water and managing surface runoff in demanding environments. These channels are ideal for areas where strength, longevity, and ease of installation are paramount.

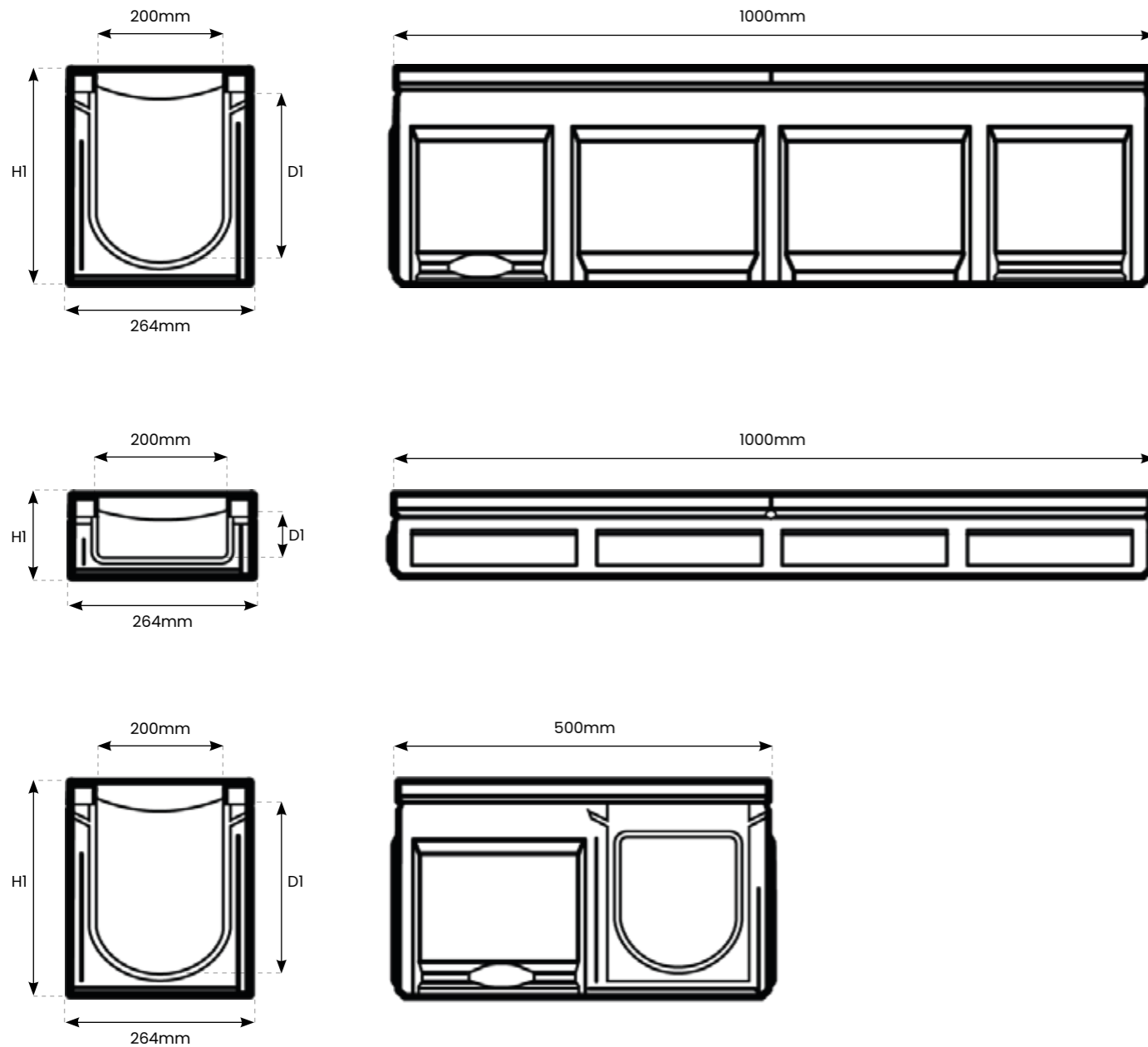

# Channel Properties

<b>Polymer concrete:</b>	<b>Polyester resin-based with mineral aggregates, additives.</b>
<b>Compressive strength:</b>	<b>&gt; 90 N/mm<sup>2</sup></b>
<b>Bending tensile strength:</b>	<b>&gt; 22 N/mm<sup>2</sup></b>
<b>Modulus of elasticity:</b>	<b>ca. 25 kN/mm<sup>2</sup></b>
<b>Density:</b>	<b>2.1 - 2.3 g/cm<sup>3</sup></b>
<b>Water penetration depth:</b>	<b>0 mm</b>
<b>Heat resistance:</b>	<b>100°C</b>
<b>Frost resistance:</b>	<b>-50°C</b>
<b>Water absorption:</b>	<b>0.05 %</b>

## Channel Types

Reference	Description	Slope	Length	Overall Width	Internal Width	Overall Depth(H1)	Internal Depth(D1)	Weight
SF.200.0	SF - 200 Channel No. 0*	0%	1000mm	264mm	200mm	290mm	270mm	48.2kg
SF.200.0R	SF - 200 Channel No. 0R***	0%	1000mm	264mm	200mm	290mm	270mm	48.2kg
SF.200.005	SF - 200 Channel No. 005**/*	0%	500mm	264mm	200mm	290mm	270mm	25.6kg
SF.200.1	SF - 200 Channel No. 1*	0.5%	1000mm	264mm	200mm	295mm	275mm	48.2kg
SF.200.2	SF - 200 Channel No. 2*	0.5%	1000mm	264mm	200mm	300mm	280mm	48.8kg
SF.200.3	SF - 200 Channel No. 3*	0.5%	1000mm	264mm	200mm	305mm	285mm	49.4kg
SF.200.4	SF - 200 Channel No. 4*	0.5%	1000mm	264mm	200mm	310mm	290mm	50kg
SF.200.5	SF - 200 Channel No. 5*	0.5%	1000mm	264mm	200mm	315mm	295mm	50.6kg
SF.200.6	SF - 200 Channel No. 6*	0.5%	1000mm	264mm	200mm	320mm	300mm	51.2kg
SF.200.7	SF - 200 Channel No. 7*	0.5%	1000mm	264mm	200mm	325mm	305mm	51.8kg
SF.200.8	SF - 200 Channel No. 8*	0.5%	1000mm	264mm	200mm	330mm	310mm	52.4kg
SF.200.9	SF - 200 Channel No. 9*	0.5%	1000mm	264mm	200mm	335mm	315mm	53kg
SF.200.10	SF - 200 Channel No. 10*	0.5%	1000mm	264mm	200mm	340mm	320mm	53.6kg
SF.200.010	SF - 200 Channel No. 010*	0%	1000mm	264mm	200mm	340mm	320mm	54kg
SF.200.010R	SF - 200 Channel No. 010R***	0%	1000mm	264mm	200mm	340mm	320mm	54kg
SF.200.0105	SF - 200 Channel No. 0105**/*	0%	500mm	264mm	200mm	340mm	320mm	29.6kg
SF.200.130P	SF - 200 Channel No. 200-P****	0%	1000mm	264mm	200mm	130mm	110mm	30.4kg
SF.200.130PR	SF - 200 Channel No. 200-PR*****	0%	1000mm	264mm	200mm	130mm	110mm	30.4kg

\* Channel with mouldings for vertical outlet DA/OD 160  
 \*\* Channel with sidewise perforations for the connection of t-junctions, elbow joints and cross-over joints  
 \*\*\* Channel with DA/OD 160 poured pipe socket  
 \*\*\*\* Channel with mouldings for vertical outlet DA/OD 110  
 \*\*\*\*\* Channel with DA/OD 110 poured pipe socket

# Accessories

## Sump Unit

Sump Units act as a reservoir, temporarily storing excess water before discharging it in a controlled manner to prevent adverse effects of water accumulation. The Sump Unit is excellent for collecting debris and waste that can get into the system. It comes with a silt bucket inside for easy cleaning.



Sump Unit

## End Cap

End Caps can be used at the end of your channel run to stop the flow of water.



End Cap

## End Cap Outlet

The End Cap Outlet can be used at the end of the run to allow water to be taken to your exterior drainage pipes and away from the channel.



End Cap Outlet

## Pipe Socket

The Pipe Socket facilitates the seamless integration of drainage channels with the underground pipe network, ensuring effective water management and preventing waterlogging or surface flooding. It essentially acts as the link between the surface drainage system and the underground drainage infrastructure.



Pipe Socket

## Accessories- Specifications

Reference	Description	Length	Height (H)	Overall Width	Weight (KG)	Outlet
SF.200.SU	SF 200 Sump Unit	500mm	700mm	264mm	61.1kg	160mm
SF.200.EC	SF 200 End Cap No. 0 - 20	20mm	130-340mm	264mm	2.8kg	-
SF.200.ECO	SF 200 End Cap Outlet No. 0 - 20	30mm	340mm	264mm	3.9kg	160mm
SF.200.PS.160	SF 200 Pipe Socket 160mm	160mm	-	160mm	0.4kg	-
SF.200.PS.200	SF 200 Pipe Socket 200mm	200mm	-	200mm	0.8kg	-

# Grating



Ductile Iron Oval Grating (F900)

## Grating Properties

Type:	OvalGrip slotted cast iron grating
Material:	EN-GJS cast iron
Length:	500mm
Inlet cross-section:	490 cm <sup>2</sup> /m, 680cm <sup>2</sup> /m, 916cm <sup>2</sup> /m, 1196 cm <sup>2</sup> /m
Fastening:	GJS Cast edge rail

# Sloped, Stepped, Level

There are 3 different scenarios in which the SF 200 drainage channel can be installed. However, the purpose of all 3 of these variations is to provide a pathway for the removal of unwanted surface water in a selected area. The specifics of which channel should be used are dependent on multiple factors such as the terrain, flow rate, and other environmental conditions.

## Sloped Invert

A channel run with a sloped invert has a consistent downward gradient along its length. The slope is designed to provide a continuous downward flow of water, allowing gravity to assist in the drainage of water. When using a sloped channel it is carefully calculated to ensure that the water will flow at an appropriate velocity to prevent sedimentation or excessive erosion.

## Stepped Invert

Stepped drainage channels are designed with a series of steps or drops along the run of the channel. These steps create a cascading effect, which helps to control the velocity of the water and prevent erosion.

## Level Invert

Level inverts are usually used in areas with relatively low slopes or insignificant water rates. They allow water to flow smoothly and evenly without the need for any significant elevation changes. Channels with a level invert are often used in urban areas, where the goal is to transport water efficiently and prevent flooding.

## Sloped Invert

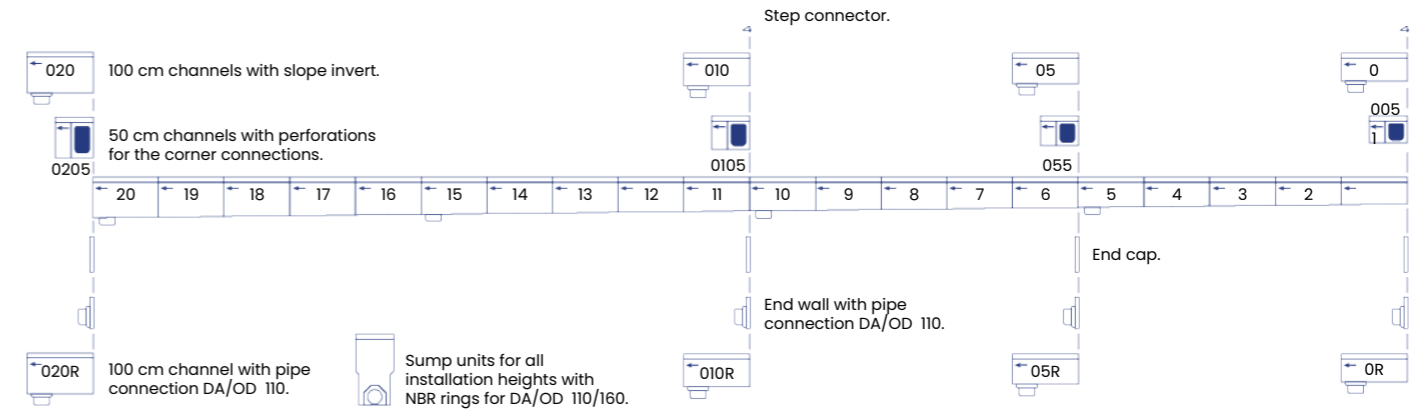

## Stepped Invert

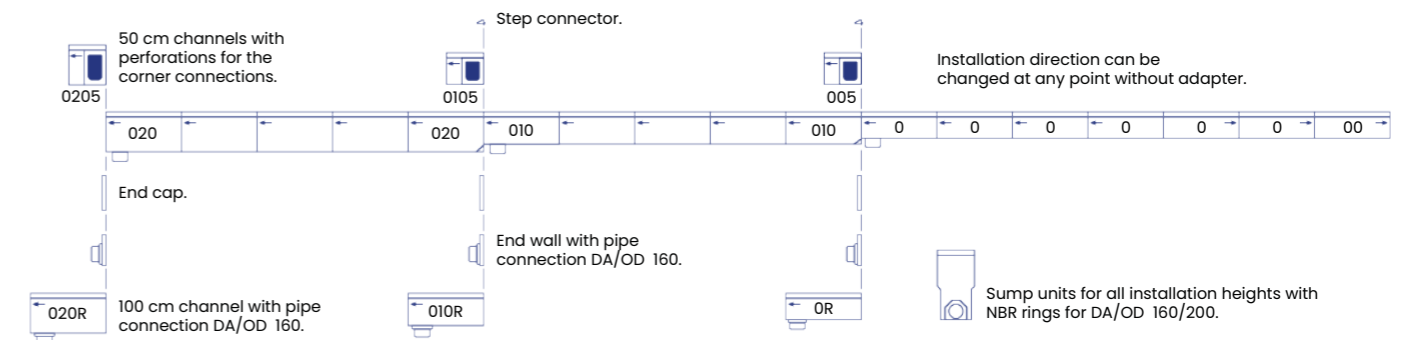

## Level Invert

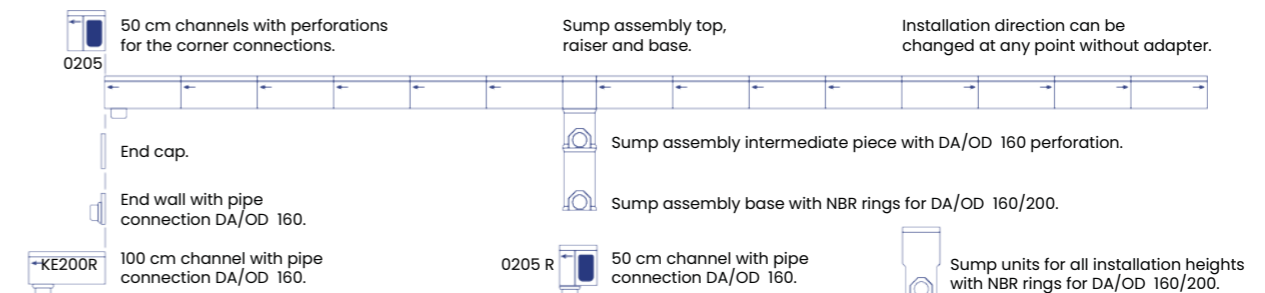

# SF 300



## SF 300

Polycon's SF 300 drainage channels are a top-notch solution for efficient water management in various settings. These channels are renowned for their quality and advanced features, making them an excellent choice for drainage needs. Here, we'll highlight the main advantages of the SF 300 drainage channels supplied by Polycon.

One of the standout features of Polycon's SF 300 channels is their innovative Unilink Joint System. This system ensures a seamless and secure connection between channel sections, eliminating weak points and preventing leaks. It simplifies installation and enhances the overall durability of the drainage system.

The SF 300 channels come equipped with a Rapid Lock Fastening system, simplifying the installation process. This feature saves time and reduces labour costs, making it a cost-effective choice for various projects.

SF 300 drainage channels are designed to withstand heavy loads and harsh conditions. Their heavy-duty construction makes them suitable for areas with high traffic, such as industrial facilities, parking lots, and commercial sites. These channels can effectively handle the demands of even the most challenging environments.

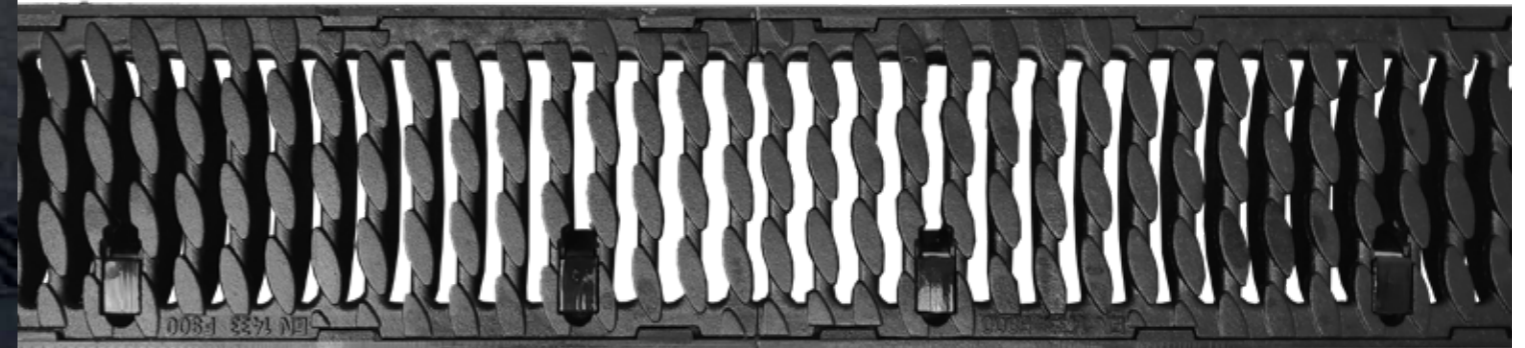

### Load Class



1.5t

A15  
1.5 tonnes



12.5t

B125  
12.5 tonnes



25t

C250  
25 tonnes



40t

D400  
40 tonnes

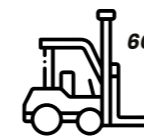

60t

E600  
60 tonnes



90t

F900  
90 tonnes

### Applications

- Civil yards
- Warehouses
- Farms
- Docks
- Loading yards
- Commercial airport
- Flight operation areas

# SF 300 - Overview

## Colour Options

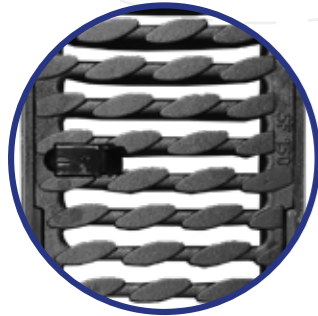

**Grating**  
4 - point locking, 90 tonne loading.

**Material**  
The SF 300 channels are constructed from polymer concrete, a material known for its exceptional strength and durability. This choice of material ensures longevity and resistance to corrosion, making them ideal for long-term use in drainage applications.

**Ductile Iron Edge Rail**  
To enhance the channels' durability and load-bearing capacity, they feature a ductile iron edge. Ductile iron is recognized for its exceptional strength and impact resistance, which extends the lifespan of the drainage channels and ensures reliability in high-stress areas.

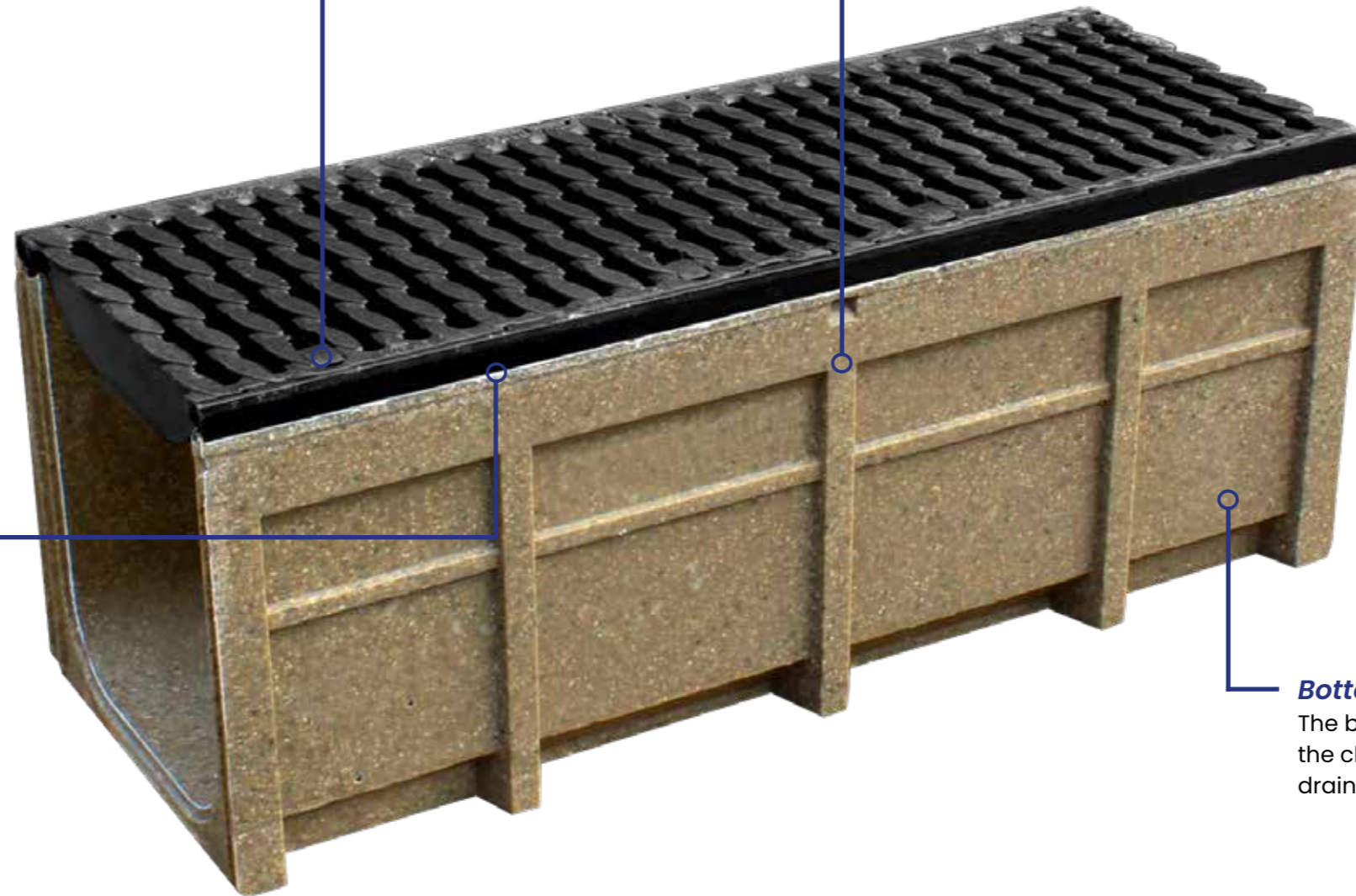

**Bottom Outlet**  
The bottom outlet in the base of the channel allows for downward drainage into a 200mm sewer connection.

## Load Classes

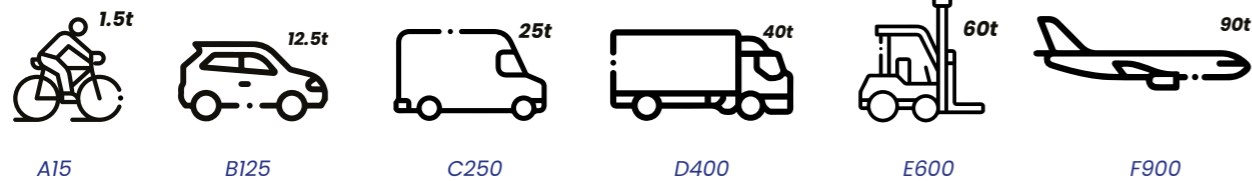

## Depth Options



# SF 300

Polycon's SF 300 drainage channels offer a comprehensive solution for effective water management. With their Unilink Joint System, heavy-duty design, polymer concrete construction, ductile iron edge, and rapid lock fastening, they provide a durable, versatile, and efficient solution for draining water and managing surface runoff in demanding environments. These channels are ideal for areas where strength, longevity, and ease of installation are paramount.

1000mm Channel Diagram

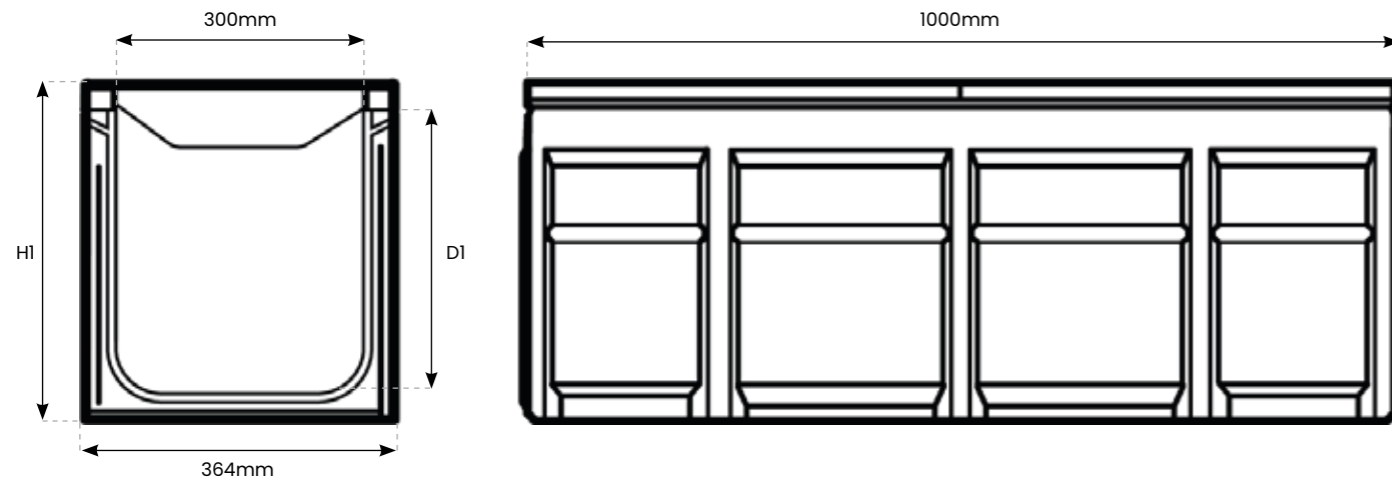

500mm Channel Diagram

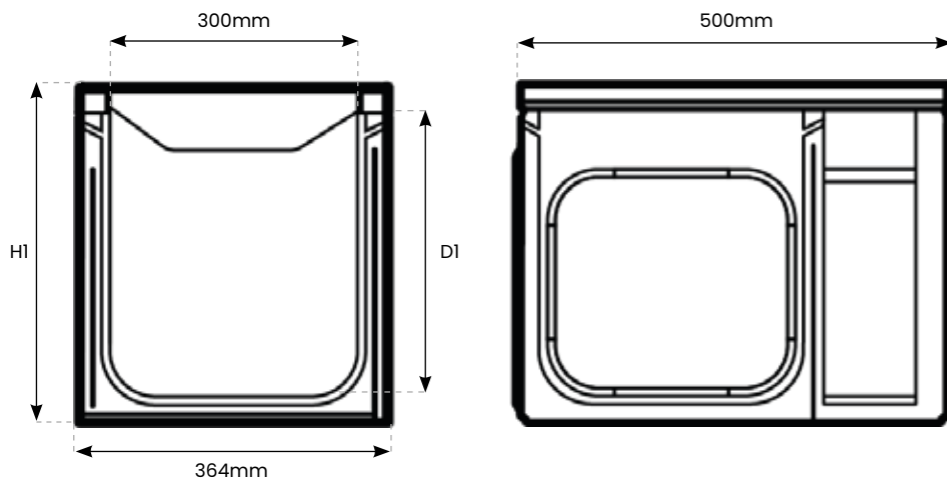

# Channel Properties

<b>Polymere concrete:</b>	<b>Polyester resin-based with mineral aggregates, additives.</b>
<b>Compressive strength:</b>	<b>&gt; 90 N/mm<sup>2</sup></b>
<b>Bending tensile strength:</b>	<b>&gt; 22 N/mm<sup>2</sup></b>
<b>Modulus of elasticity:</b>	<b>ca. 25 kN/mm<sup>2</sup></b>
<b>Density:</b>	<b>2.1 - 2.3 g/cm<sup>3</sup></b>
<b>Water penetration depth:</b>	<b>0 mm</b>
<b>Heat resistance:</b>	<b>100°C</b>
<b>Frost resistance:</b>	<b>-50°C</b>
<b>Water absorption:</b>	<b>0.05 %</b>

## Channel Types

Reference	Description	Length	Overall Width	Internal Width	Overall Depth (H1)	Internal Depth (D1)	Weight
SF.300	SF - 300 Channel*	1000mm	364mm	300mm	390mm	370mm	64kg
SF.300.R	SF - 300 Channel R***	1000mm	364mm	300mm	390mm	370mm	64kg
SF.300.5	SF - 300 Channel /5**/*	500mm	364mm	300mm	390mm	370mm	35kg
SF.300.160.P	SF - 300 Channel P*	1000mm	364mm	300mm	160mm	140mm	46kg
SF.300.160.PR	SF - 300 Channel PR*	1000mm	364mm	300mm	160mm	140mm	46kg

\* Channel with mouldings for vertical outlet DA/OD 200  
 \*\* Channel with sidwise perforations for the connection of t-junctions, elbow joints and cross-over joints  
 \*\*\* Channel with DA/OD 200 poured pipe socket



# Accessories

## Sump Unit

Sump Units act as a reservoir, temporarily storing excess water before discharging it in a controlled manner to prevent adverse effects of water accumulation. The Sump Unit is excellent for collecting debris and waste that can get into the system. It comes with a silt bucket inside for easy cleaning.



Sump Unit

## End Cap

End Caps can be used at the end of your channel run to stop the flow of water.



End Cap

## End Cap Outlet

The End Cap Outlet can be used at the end of the run to allow water to be taken to your exterior drainage pipes and away from the channel.



End Cap Outlet

## Pipe Socket

The Pipe Socket facilitates the seamless integration of drainage channels with the underground pipe network, ensuring effective water management and preventing waterlogging or surface flooding. It essentially acts as the link between the surface drainage system and the underground drainage infrastructure.



Pipe Socket

## Accessories- Specifications

Reference	Description	Length	Height (H)	Overall Width	Weight (KG)	Outlet
SF.300.SUT	SF 300 Sump Unit Top	500mm	390mm	364mm	30kg	200mm
SF.300.SUB	SF 300 Sump Unit Base	480mm	645mm	330mm	43.2kg	200mm
SF.300.EC	SF 300 End Cap	20mm	160-390mm	364mm	5.2kg	-
SF.300.ECO	SF 300 End Cap Outlet	30mm	390mm	364mm	9.1kg	200mm
SF.300.PS.160	SF 300 Pipe Socket 160mm	160mm	-	160mm	0.6kg	-
SF.300.PS.200	SF 300 Pipe Socket 200mm	200mm	-	200mm	0.8kg	-

# Grating



Ductile Iron Oval Grating (F900)

## Grating Properties

Type:	OvalGrip slotted cast iron grating
Material:	EN-GJS cast iron
Length:	500mm
Inlet cross-section:	490 cm <sup>2</sup> /m, 680cm <sup>2</sup> /m, 916cm <sup>2</sup> /m, 1196 cm <sup>2</sup> /m
Fastening:	GJS Cast edge rail

# Installation Guide

Ground conditions must be suitable and all dimensions shown are the minimum requirement. Engineering advice should be taken where necessary and any questions should be directed to Polycon's technical team by emailing us at [sales@polycon.co.uk](mailto:sales@polycon.co.uk) or by calling us on **0151 424 9747**.

1	2	3	4	5	6
Concrete	Sub Base	Earth	Concrete Haunch	Sand Layer	Expansion Joint

**Block Paving**

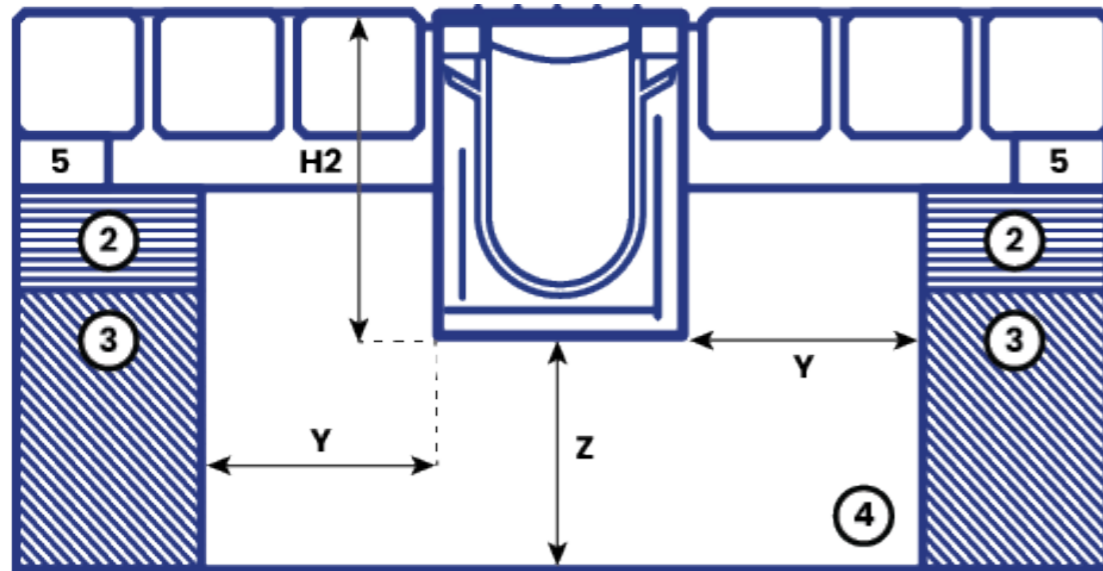

**Tarmac**

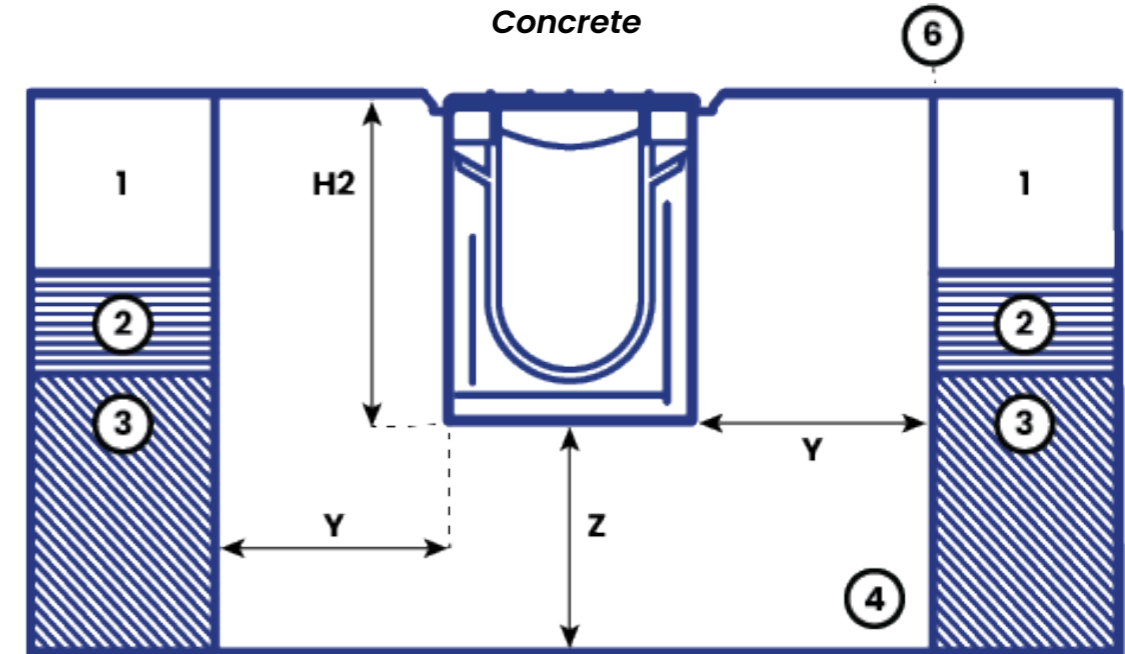
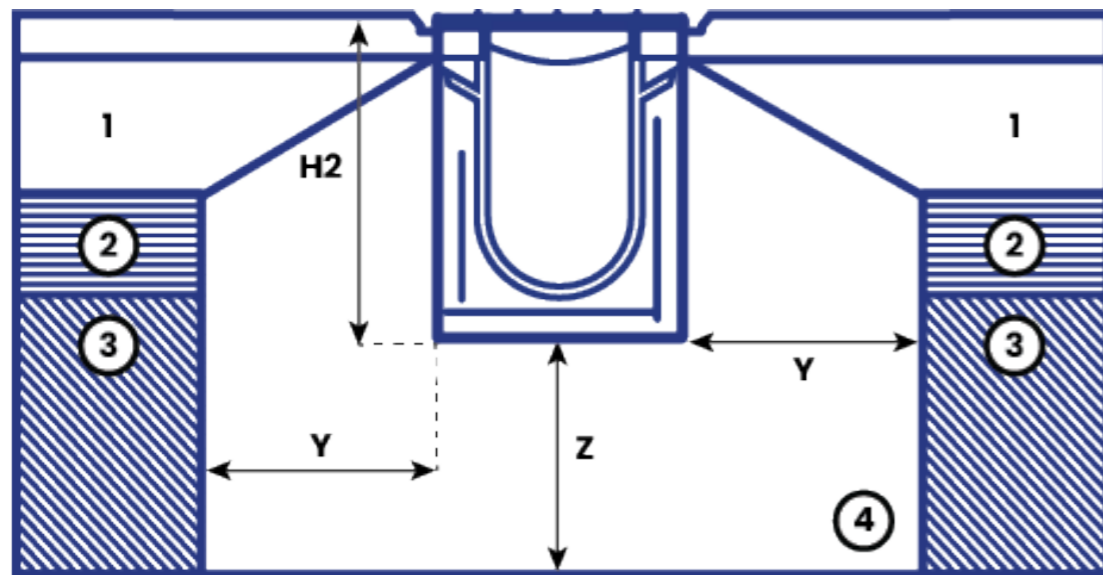

Load Class	A15	B125	C250	D400	E600	F900
H2 - Channel Height	Channel Height	Channel Height	Channel Height	Channel Height	Channel Height	Channel Height
Y - Minimum Surround	100mm	150mm	150mm	200mm	200mm	250mm
Z - Minimum Surround	100mm	150mm	150mm	200mm	200mm	250mm
T1 - Minimum Depth	40mm	40mm	40mm	40mm	40mm	40mm
T2 - Maximum Depth	95mm	55mm	55mm	55mm	55mm	55mm

\*\* Minimum Concrete Haunch 25 N/mm<sup>2</sup>.  
Detail A allow for overbuild of 3mm to 5mm above the grating surfaces.





**Polycon Surface Water Drainage**

**Widnes Business Park  
Foundry Lane  
Widnes  
Cheshire  
WA8 8UB**

**[www.polycon.co.uk](http://www.polycon.co.uk)  
0151 422 9747  
[sales@polycon.co.uk](mailto:sales@polycon.co.uk)**

*Service . Range . Knowledge*