



**polycon**  
surface water drainage

**SF 150**

**DATASHEET**

*Service . Range . Knowledge*

# SF 150

Polycon's SF 150 drainage channels offer a comprehensive solution for effective water management. With their Unilink Joint System, heavy-duty design, polymer concrete construction, ductile iron edge, and rapid lock fastening, they provide a durable, versatile, and efficient solution for draining water and managing surface runoff in demanding environments. These channels are ideal for areas where strength, longevity, and ease of installation are paramount.



## 1000mm Channel Diagram

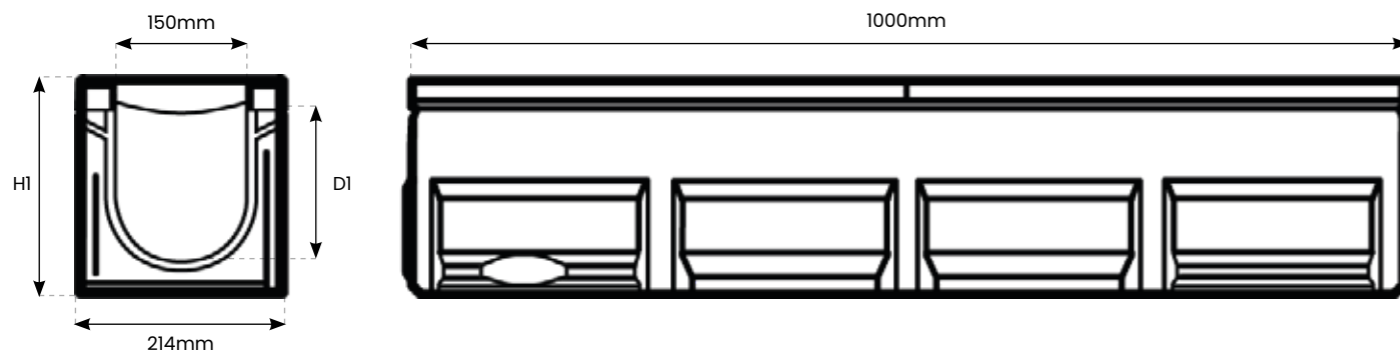

## 500mm Channel Diagram

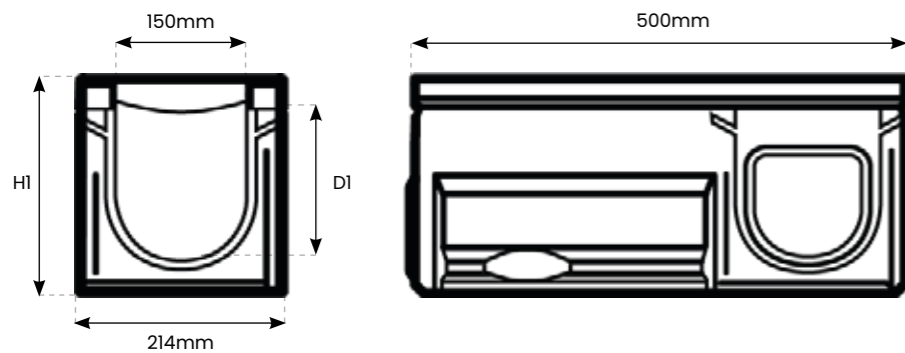

<b>Polymere concrete:</b>	Polyester resin-based with mineral aggregates, additives.
<b>Compressive strength:</b>	> 90 N/mm <sup>2</sup>
<b>Bending tensile strength:</b>	> 22 N/mm <sup>2</sup>
<b>Modulus of elasticity:</b>	ca. 25 kN/mm <sup>2</sup>
<b>Density:</b>	2.1 - 2.3 g/cm <sup>3</sup>
<b>Water penetration depth:</b>	0 mm
<b>Heat resistance:</b>	100°C
<b>Frost resistance:</b>	-50°C
<b>Water absorption:</b>	0.05 %

## Channel Types

Reference	Description	Slope	Length	Overall Width	Internal Width	Overall Depth(H1)	Internal Depth(D1)	Weight
SF.150.0	SF - 150 Channel No. 0*	0%	1000mm	214mm	150mm	220mm	200mm	30kg
SF.150.0R	SF - 150 Channel No. 0R***	0%	1000mm	214mm	150mm	220mm	200mm	30kg
SF.150.005	SF - 150 Channel No. 005**/*	0%	500mm	214mm	150mm	220mm	200mm	17kg
SF.150.1	SF - 150 Channel No. 1*	0.5%	1000mm	214mm	150mm	225mm	205mm	33.4kg
SF.150.2	SF - 150 Channel No. 2*	0.5%	1000mm	214mm	150mm	230mm	210mm	33.8kg
SF.150.3	SF - 150 Channel No. 3*	0.5%	1000mm	214mm	150mm	235mm	215mm	34.2kg
SF.150.4	SF - 150 Channel No. 4*	0.5%	1000mm	214mm	150mm	240mm	220mm	34.6kg
SF.150.5	SF - 150 Channel No. 5*	0.5%	1000mm	214mm	150mm	245mm	225mm	35kg
SF.150.6	SF - 150 Channel No. 6*	0.5%	1000mm	214mm	150mm	250mm	230mm	35.4kg
SF.150.7	SF - 150 Channel No. 7*	0.5%	1000mm	214mm	150mm	255mm	235mm	35.8kg
SF.150.8	SF - 150 Channel No. 8*	0.5%	1000mm	214mm	150mm	260mm	240mm	36.2kg
SF.150.9	SF - 150 Channel No. 9*	0.5%	1000mm	214mm	150mm	265mm	245mm	36.6kg
SF.150.10	SF - 150 Channel No. 10*	0.5%	1000mm	214mm	150mm	270mm	250mm	37kg
SF.150.010	SF - 150 Channel No. 010*	0%	1000mm	214mm	150mm	270mm	250mm	37kg
SF.150.010R	SF - 150 Channel No. 010R*	0%	1000mm	214mm	150mm	270mm	250mm	37kg
SF.150.0105	SF - 150 Channel No. 0105**/*	0%	500mm	214mm	150mm	270mm	250mm	18.8kg

\* Channel with mouldings for vertical outlet DA/OD 160

\*\* Channel with sidewise perforations for the connection of t-junctions, elbow joints and cross-over joints

\*\*\* Channel with vertical pipe socket DA/OD 160



## Accessories- Specifications

Reference	Description	Length	Height (H)	Overall Width	Weight (KG)	Outlet
SF.150.SU	SF 150 Sump Unit	500mm	620mm	214mm	55.1kg	110mm
SF.150.EC	SF 150 End Cap No. 0 - 20	20mm	165-265mm	214mm	2.5kg	-
SF.150.ECO	SF 150 End Cap Outlet No. 0 - 20	30mm	220mm	214mm	3.4kg	110mm
SF.150.PS.160	SF 150 Pipe Socket 160mm	160mm	-	160mm	0.4kg	-
SF.150.PS.200	SF 150 Pipe Socket 200mm	200mm	-	200mm	0.8kg	-



## Grating Properties

<b>Type:</b>	OvalGrip slotted cast iron grating
<b>Material:</b>	EN-GJS cast iron
<b>Length:</b>	500mm
<b>Inlet cross-section:</b>	490 cm <sup>2</sup> /m, 680cm <sup>2</sup> /m, 916cm <sup>2</sup> /m, 1196 cm <sup>2</sup> /m
<b>Fastening:</b>	GJS Cast edge rail



**Polycon Surface Water Drainage**

**Widnes Business Park  
Foundry Lane  
Widnes  
Cheshire  
WA8 8UB**

**[www.polycon.co.uk](http://www.polycon.co.uk)  
0151 422 9747  
[sales@polycon.co.uk](mailto:sales@polycon.co.uk)**

***Service . Range . Knowledge***