



MonoBlock DM1500

DATASHEET

Service . Range . Knowledge

MonoBlock DM 1500

The MonoBlock system is a remarkable innovation, featuring a monolithic design that eliminates the need for adhesive joints or gaps between the channel and grating, thereby enhancing its robustness and damage resistance. Crafted from Polymer Concrete, this system offers a unique blend of durability, water resistance, wear resistance, corrosion resistance, and high impact endurance, making it an ideal choice for long-term installations.



MonoBlock DM 1500

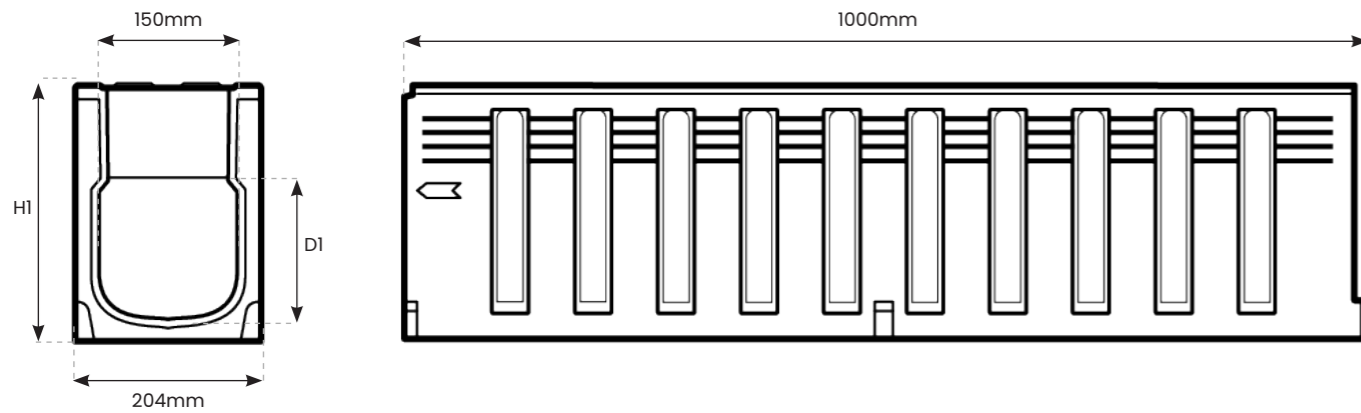

MonoBlock DM 1500 - Specifications

Reference	Description	Pallet Quantity	Length	Internal Width	Overall Width	Overall Depth(HI)	Internal Depth(DI)	Load Class
MB.DM.1500	MonoBlock DM 1500	12	1000mm	150mm	204mm	280mm	160mm	A/B/C/D/E/F

Access Unit & Grate

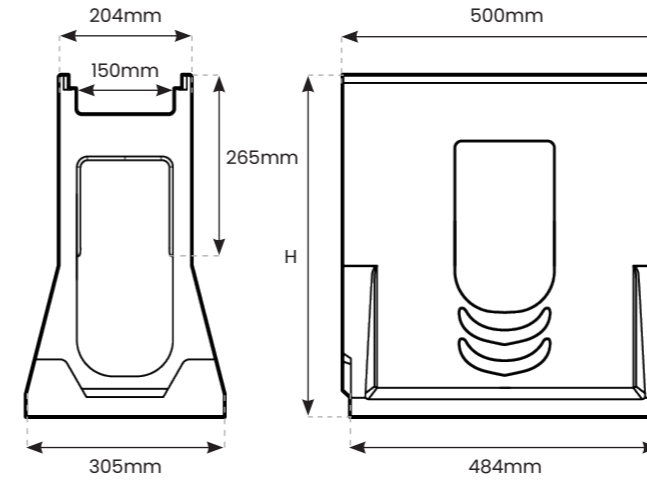

End Cap



Sump unit lower

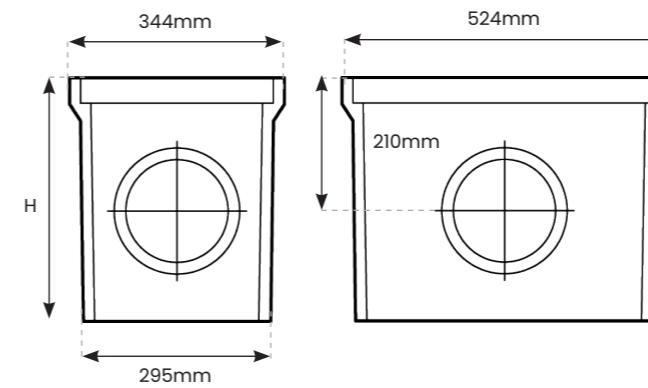

Sump unit upper

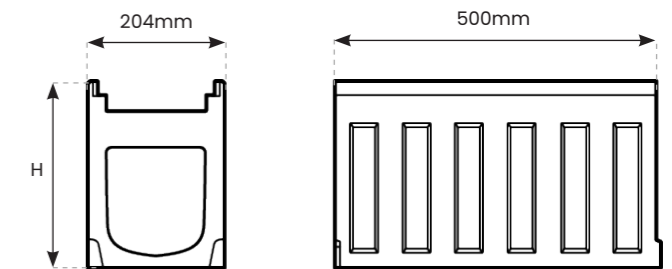

Accessories- Specifications

Reference	Description	Length	Height (H)	Overall Width	Outlet
MB.DM.1500.SU.UP.DI	MonoBlock DM 1500 Sump Unit Upper Part + Ductile Iron Grating	500mm	280mm	204mm	-
MB.DM.1500.SU.LP.DI	MonoBlock DM 1500 Sump Unit Lower Part + Ductile Iron Grating	524mm	390mm	344mm	-
MB.DM.1500.SU.160.DI	MonoBlock DM 1500 Sump Unit Lower Part + 160 Ø + Ductile Iron Grating	524mm	335mm	495mm	160mm
MB.DM.1500.SU.200.DI	MonoBlock DM 1500 Sump Unit Lower Part + 200 Ø + Ductile Iron Grating	524mm	335mm	495mm	200mm
MB.DM.1500.AU.DI	MonoBlock DM 1500 Access Unit + Ductile Iron Grating	500mm	528mm	305mm	-
MB.DM.1500.EC.GS	MonoBlock DM 1500 End Cap Galvanised Steel	5mm	280mm	200mm	-



Polycon Surface Water Drainage

**Widnes Business Park
Foundry Lane
Widnes
Cheshire
WA8 8UB**

**www.polycon.co.uk
0151 422 9747
sales@polycon.co.uk**

Service . Range . Knowledge