



LITE *Prem 200*

Service . Range . Knowledge



Welcome To Polycon

Polycon is identified as one of the leading manufacturers, distributors, and suppliers of channel drainage in the UK. We focus on creating a diverse range of water solutions, in various materials, including composite, polymer concrete, SMC, and steel.

Polycon's unique look at the market and expert knowledge of the industry ensures we can supply a wide range of high-quality products suitable for any application. This includes building drainage, landscaping, sports facilities, distribution centres, highways, and airports.

Our design team provides innovative and efficient hydraulic solutions to ensure we can offer your drainage needs the best product/solution. We have a vast and experienced overview of our working industry and have been manufacturing, distributing, and selling channel drainage for over 8 years. We thrive on acting upon your feedback to improve and develop our products to fit flawlessly with the constantly changing market and demand from our customers.

At Polycon we focus our attention on professionals who sit within the construction industry, targeting our products to specifiers, architects, engineers, and contractors. Therefore, we understand the importance of expanding our product portfolio to create the most efficient surface water drainage systems.

We are a dynamic and evolving company with a focus on quality, innovation, and service. As a result, you can rely on us to handle your project needs in every way to the best of our ability.

Contents

<i>Lite Prem 200</i>	3
<i>Lite Prem 200 - Overview</i>	5
<i>Lite Prem 200 - Accessories</i>	7

Service • Range • Knowledge

LITE Prem 200

The Lite Prem 200 channel supplied by Polycon boasts exceptional benefits that set it apart as a top choice for drainage solutions. The Lite Prem 200 system has been designed and manufactured from High-Density Polyethylene (HDPE). This has many features and benefits, tailored for high-performance drainage systems and efficient water flow.

The material properties mean the Lite Prem system can withstand significant impacts and creates a long-lasting life cycle without aggressive maintenance. One of the standout features of the Lite Prem 200 channel is its remarkable chemical resistance.

Whether it encounters aggressive chemicals or corrosive substances, this channel remains unfazed, maintaining its structural integrity and functionality. Its smooth, waterproof surface enhances its versatility and ease of maintenance, preventing water from pooling in unwanted areas.

Regarding efficient water management, the Lite Prem 200 channel truly excels. Its quick water flow capability ensures rapid drainage, minimising the risk of water pooling and related issues. With a magnitude of different depths, the Lite Prem 200 has the flexibility to customise drainage solutions to suit specific needs.

*Conformity Manufactured in compliance with ISO 9001:2000
Certified in compliance with EN1433 Fully CE Certified with the
declaration of performance certificate.*



Load Classes



A15
1.5 tonnes

Applications

- Landscaping Areas
- Pedestrian Areas

LITE Prem200



LITE Prem 200 – Overview

Channel Colour Options

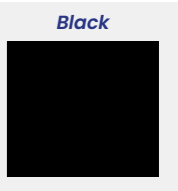

Stainless Steel Edge Rail

The Lite Prem 200 drainage channel can be equipped with a stainless steel edge rail, which significantly enhances both the durability and load-bearing strength of the system. By reinforcing the channel edges, the stainless steel rail protects against wear and tear from frequent use, making it ideal for environments with increased traffic demands. This added strength not only extends the life of the drainage system but also provides greater stability under pressure, reducing the risk of deformation or damage over time.

Channel Size Options

There is an array of depth options, providing consumers with unparalleled flexibility to tailor their drainage solutions to specific requirements. With six diverse size choices available, ranging from 195mm to 550mm depths, customers can select the perfect dimensions to match their project's needs.

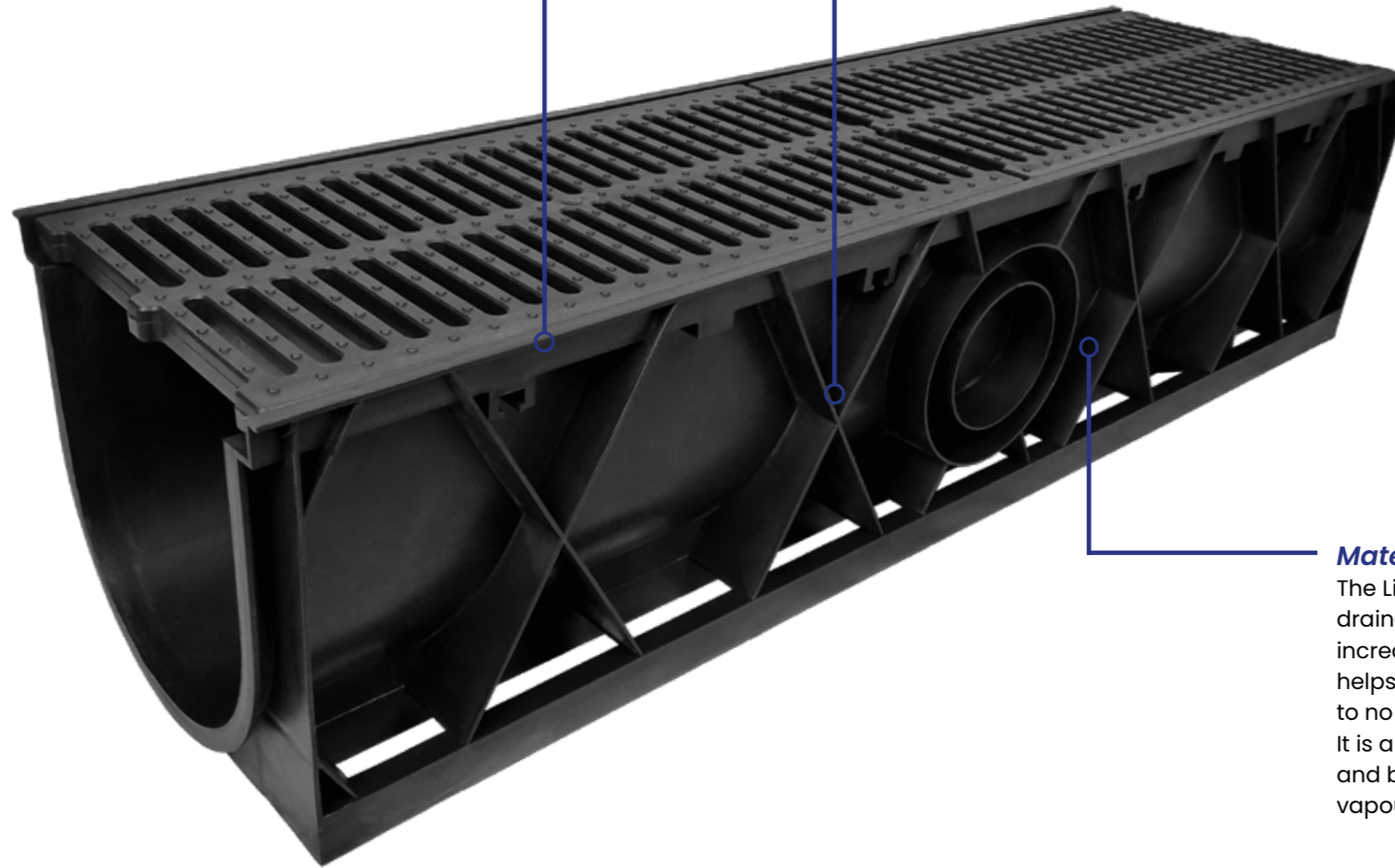

Material

The Lite Prem 200 is a lightweight plastic drainage channel. The material is both incredibly light and has a strong exterior. This helps to reduce labour expenses because little to no machinery is required for installation. It is a long-lasting option for urban projects, and because of its improved protection, water vapour cannot pass through it.

Load Classes



A15

Depth Options



240mm

LITE Prem Plus – 200

The Lite Prem 200 is a durable, flexible, lightweight drainage system with A15 load capacity. An optional attachable edge rail provides additional strength and durability, making it highly adaptable.

Lite Prem Plus 200 – Diagram

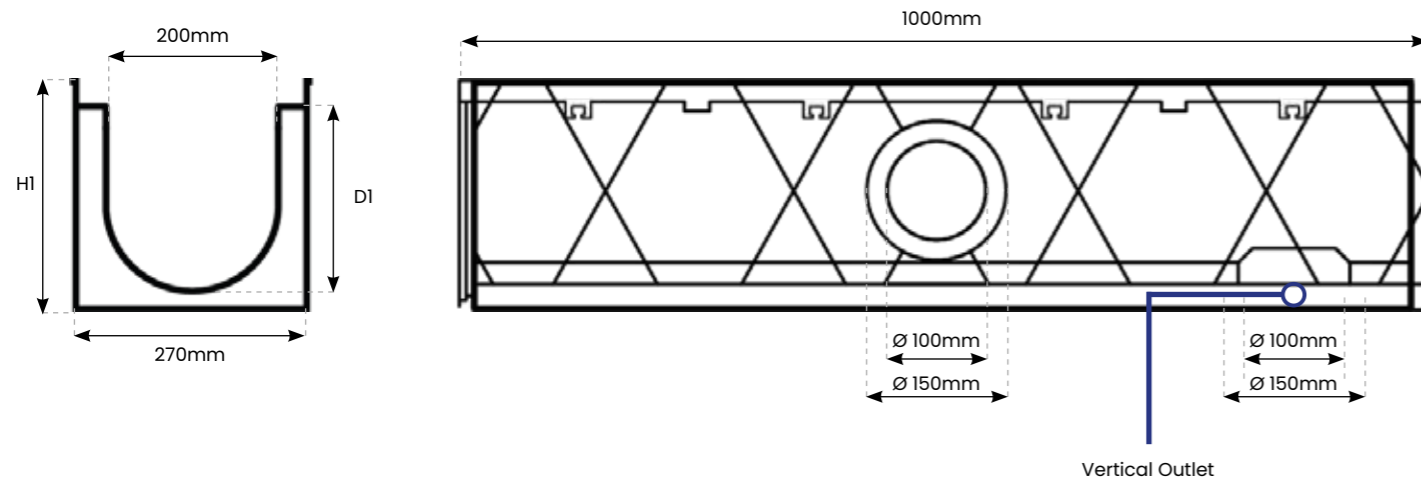

Grating



Composite Slotted Black (A15)



Composite Slotted Black + Stainless Steel Edge Rail (A15)

* The Lite Prem Plus channel, without the edge rail, supports load classes from A15 to C250, depending on the grating used.
 ** The channel itself can handle up to F900, but to achieve any load class from C250 to F900, the channel must be equipped with the optional edge rail for enhanced performance and strength.

Lite Prem Plus 200 – Specifications

Reference	Description	Overall Depth (H1)	Internal Depth (D1)	Overall Width	Internal Width	Length	Vertical Outlet	Load Class
LPP.200.CSB	Lite Prem Plus 200 Composite Slotted Black Grating	240mm	220mm	270mm	200mm	1000mm	100/150mm	A15
LPP.200.CSB.ER	Lite Prem Plus 200 + Edge Rail Composite Slotted Black Grating	240mm	220mm	275mm	200mm	1000mm	100/150mm	A15

Accessories

Stainless Steel Edge Rail

The edge rail is made from 1mm thick stainless steel for lateral channel protection. Every 1m channel requires 2 steel edge rails.



Stainless Steel Edge Rail

Corner Unit

Corner units allow for an easy change in the direction of the channel, providing a smooth transition and enhancing the system's flexibility.



Composite Corner Unit

End Cap & Outlet

End caps are used at the end of the channel run to stop the flow of water.



End Cap Outlet

Bolt & Bar

A bolt and bar mechanism is utilised for added security, effectively locking the grating in place for enhanced stability.



Bolt & Bar

Side Clamp

A 1 metre channel requires 8 stainless steel side clamps for secure attachment to the concrete.



Side Clamp

Accessories – Specifications

Reference	Description	Height	Overall Width	Length	Outlet
CU.LPP.200	Lite Prem Plus 200 Corner Unit	240mm	295mm	295mm	-
ECO.LPP.200	Lite Prem Plus 200 End Cap Outlet	233mm	265mm	28mm	100/150mm
LPP.200.CSBG	Lite Prem Plus 200 Composite Slotted Black Grating	19mm	240mm	500mm	-



Polycon Surface Water Drainage

**Widnes Business Park
Foundry Lane
Widnes
Cheshire
WA8 8UB**

**www.polycon.co.uk
0151 422 9747
sales@polycon.co.uk**

Service . Range . Knowledge