



# **HIGHWAY** RANGE

*Service . Range . Knowledge*



## Welcome To Polycon

Polycon is identified as one of the leading manufacturers, distributors, and suppliers of channel drainage in the UK. We focus towards creating a diverse range of water solutions, in a variety of different materials, including composite, polymer concrete, SMC, and steel.

Polycon's unique look at the market and expert knowledge of the industry ensures that we can supply a wide range of high-quality products suitable for any application. This includes building drainage, landscaping, sports facilities, distribution centres, highways, and airports.

Our design team provides innovative and efficient hydraulic solutions to ensure we can offer the best product/ solution for your drainage needs. We have a vast and experienced overview of our working industry and have been manufacturing, distributing, and selling channel drainage for over 8 years. We thrive on acting upon your feedback to improve and develop our products to fit flawlessly with the constantly changing market and demand from our customers.

At Polycon we focus our attention on professionals who sit within the construction industry, targeting our products to specifiers, architects, engineers, and contractors. Therefore, we understand the importance of expanding our product portfolio to create the most efficient surface water drainage systems.

We are a dynamic and evolving company with a focus on quality, innovation, and service. As a result, you can rely on us to handle your project needs in every way to the best of our ability.

## Contents

<i>PolyKerb</i>	3
<i>MonoChannel</i>	11
<i>SafetiCurb</i>	21
<i>MonoBlock DM1000</i>	37
<i>MonoBlock DM1500</i>	43
<i>MonoBlock DM2000</i>	49

**Service • Range • Knowledge**



# PolyKerb

PolyKerb, a revolutionary product in the realm of construction and infrastructure, stands out as a beacon of innovation with its exceptional qualities. A subset of Polycons, PolyKerb is designed to bring about significant improvements in cost efficiency, environmental sustainability, and overall safety in construction projects. One of its primary advantages lies in its ability to substantially reduce costs associated with traditional kerbing systems. By employing PolyKerb, construction projects can achieve substantial savings without compromising on the quality and durability of the result.

One of Polykerb's standout features is its commitment to environmental responsibility. With an impressive 70% recycled material content in every 500mm unit, Polykerb makes a bold statement about sustainability in construction.

This emphasis on recycled content not only reduces the demand for new raw materials but also minimizes the environmental footprint of construction projects. This aligns with the growing global awareness of the importance of utilizing recycled materials to curb resource depletion and mitigate environmental impact.

Furthermore, PolyKerb distinguishes itself by being notably lighter than traditional kerbing systems. This characteristic not only facilitates easier handling during installation but also contributes to reduced transportation costs. The lightweight nature of PolyKerb makes it a more practical and efficient choice for construction projects, where time and labour are critical factors.



## Load Class



A15  
1.5 tonnes



B125  
12.5 tonnes

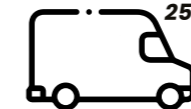

C250  
25 tonnes



D400  
40 tonnes

## Applications

- Roundabouts
- Motorways
- Roads
- Highly trafficked areas

# PolyKerb - Overview

## Colour Options

Grey

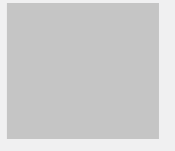

### Hydraulic System

The combination of a large usable volume and hydraulically efficient material means PolyKerb creates fast flows and good silt transit. This aids the longevity of the structure, system, and product, reducing the frequency of future maintenance.

### Material

The PolyKerb drainage channel sets a new standard in sustainable construction by incorporating 70% recycled materials into every unit. This innovative design not only ensures efficient water management but also significantly reduces the environmental impact of the project.

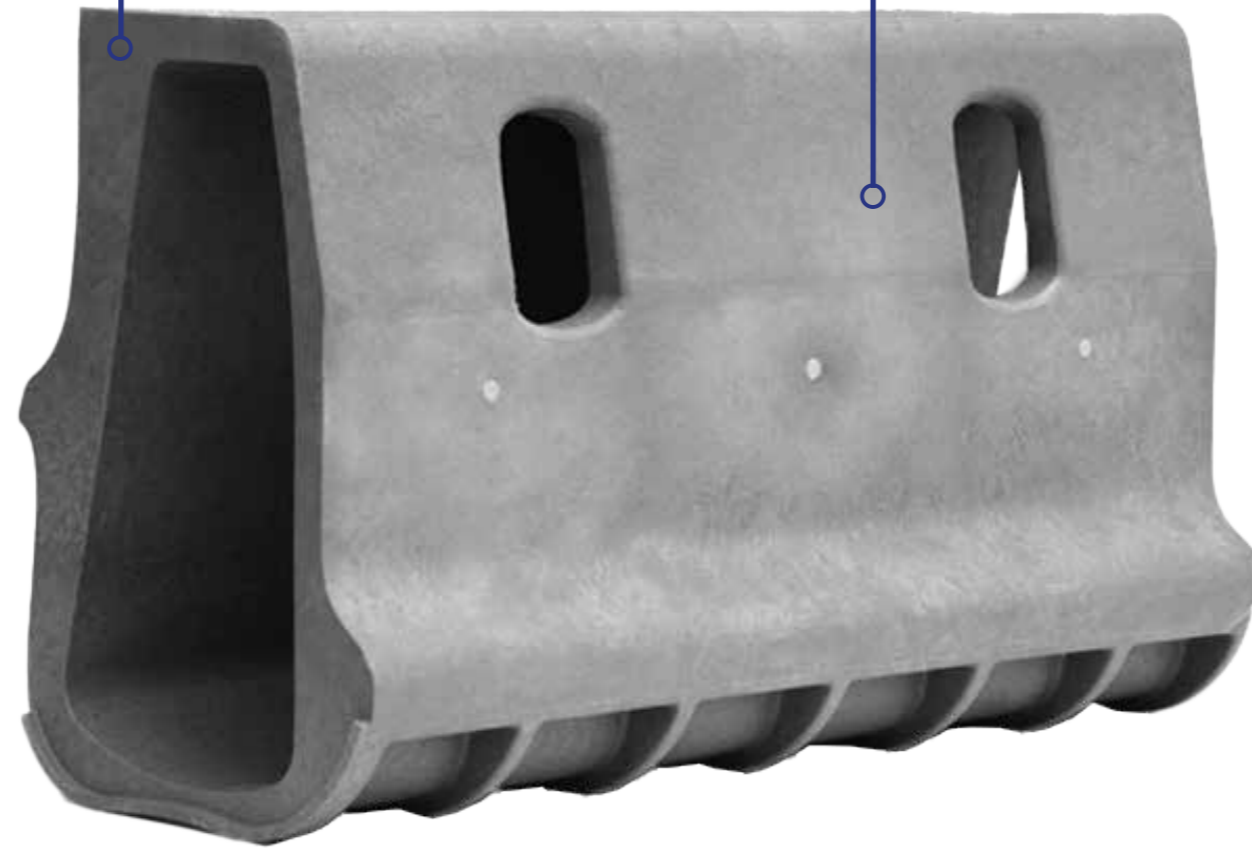

### Load Classes



1.5t

A15



12.5t

B125

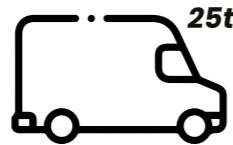

25t

C250



40t

D400

### Kerb Options



Drainable Centre



Centre Kerb



Lower Drop Kerb



Upper Drop Kerb



Splay Kerb Drain



HB Kerb Drain

# PolyKerb

PolyKerb has a range of benefits from cost reduction and the extensive use of recycled materials, to being lighter, safer, and more sustainable, positioning it as a trailblazer in the pursuit of a greener and more efficient construction industry. As the demand for eco-friendly and cost-effective solutions continues to rise, PolyKerb emerges as a compelling choice for construction projects aiming to balance economic viability with environmental responsibility.

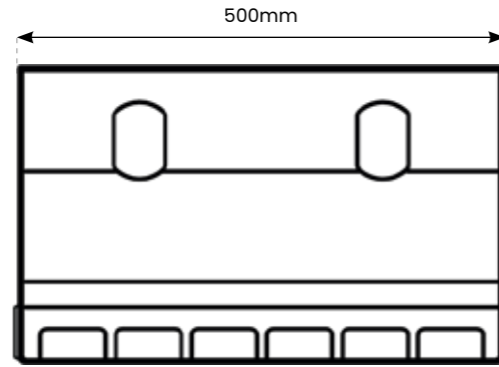
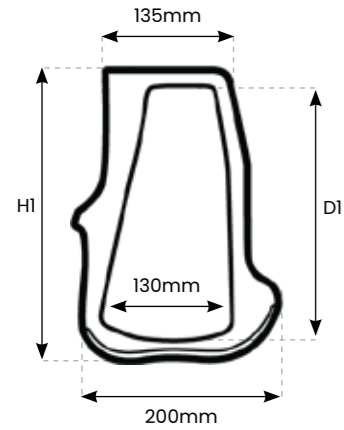

HB Kerb Drain Diagram

## HB Kerb Drain

The recycled & recyclable lightweight standard units are manufactured from a hydraulically efficient material and have a large useable volume.

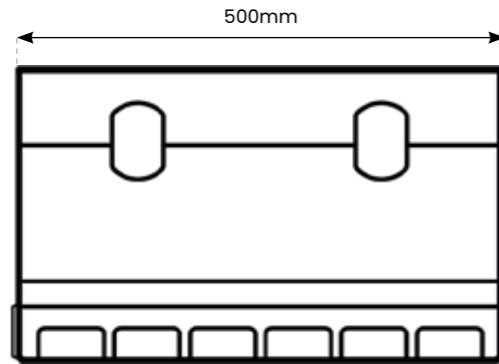
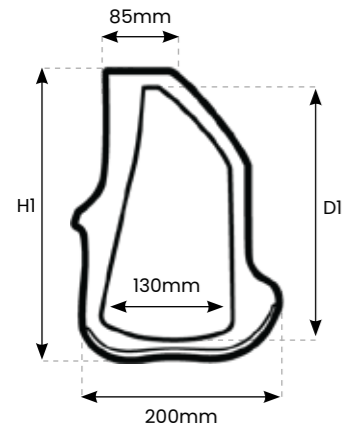

Splay Kerb Drain Diagram

## Splay Kerb Drain

Our Splayed Profile Kerb Drain is to be used in situations where vehicles may need to "bump up" onto a verge in an emergency.

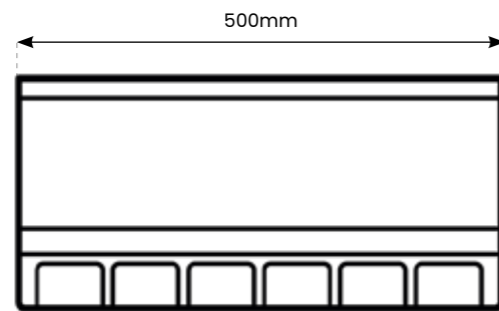
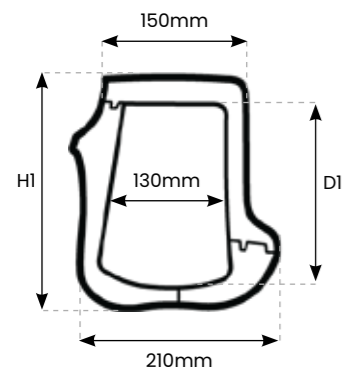

Centre Kerb Diagram

## Centre Kerb

PolyKerb centre stones can be supplied plain or with vertical 8mm pedestrian-friendly inlets to maintain drainage intake through the drop.

## PolyKerb - Specifications

Reference	Description	Kerb Show	Length	Internal Width	Overall Width	Overall Depth(HI)	Internal Depth(DI)	Load Class
PK.HBKD	Half Battered Kerb Drain	75-125mm	500mm	130mm	220mm	305mm	265mm	A/B/C/D
PK.SKD	Splay Kerb Drain	75-100mm	500mm	130mm	215mm	305mm	265mm	A/B/C/D
PK.UDK	Upper Drop Kerb L/R	100/175mm	500mm	130mm	215mm	305-255mm	255mm	A/B/C/D
PK.LDK	Lower Drop Kerb L/R	100/175mm	500mm	130mm	215mm	255-205mm	210mm	A/B/C/D
PK.CK	Centre Kerb	0-25mm	500mm	130mm	215mm	205mm	165mm	A/B/C/D
PK.DCK	Drainable Centre Kerb	0-25mm	500mm	130mm	215mm	205mm	165mm	A/B/C/D

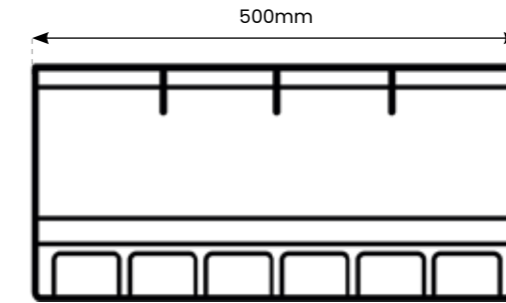
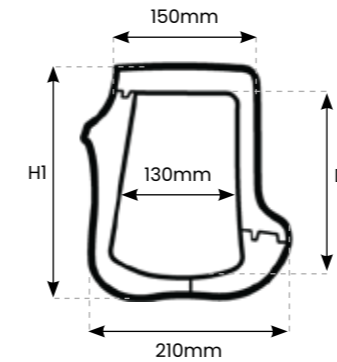

Drainable Centre Kerb Diagram

## Drainable Centre Kerb

PolyKerb centre stones can be supplied plain or with vertical 8mm pedestrian-friendly inlets to maintain drainage intake through the drop.

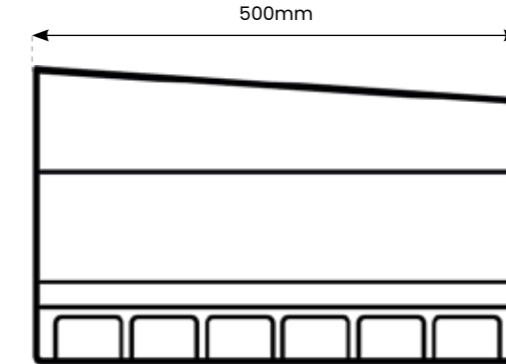
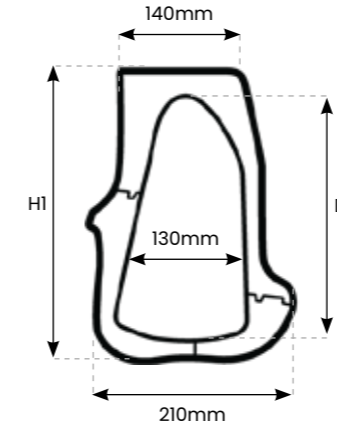

Upper Drop Kerb L/R Diagram

## Upper Drop Kerb L/R

Upper drop kerbs are designed to link the standard unit to the Lower Drop Kerb pictured. This allows the standard unit to be used in conjunction with a centre stone for areas where a lower kerb is required.

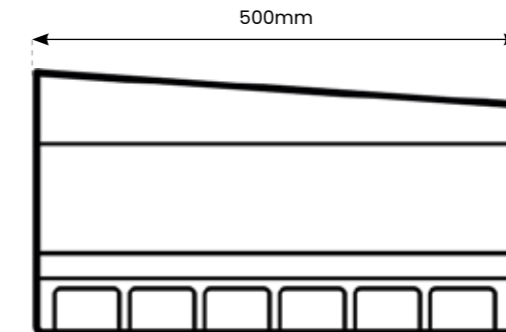
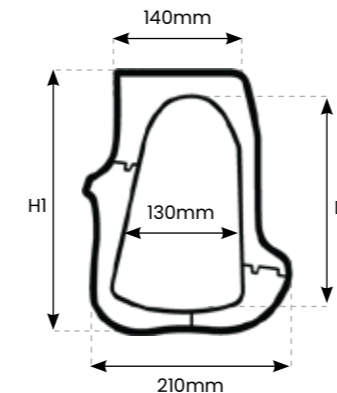

Lower Drop Kerb L/R Diagram

## Lower Drop Kerb L/R

Lower Drop Kerbs are designed to link the Upper Drop Kerb to the Centre Stone. This allows the standard unit to be used in conjunction with a centre stone for areas where a lower kerb is required.

# Accessories

## Half Battered Access Unit

Solid ductile iron access points can be installed at the head of each run and at regular intervals subject to site conditions. Units can also be used as robust shallow or intermediate outlet points.



Half Battered Access Unit

## Splay Access Unit

Solid ductile iron access points can be installed at the head of each run and at regular intervals subject to site conditions. Units can also be used as robust shallow or intermediate outlet points.



Splay Access Unit

## Corner Units

Corner units can be used to create perfect 90-degree angles in your drainage runs without the need to mitre on site.



Corner Units

## HB & Splay End Caps

Universal end caps can be fitted to access/outlets and standard units. Simply apply sealant up the window/entry height and fix it. Caps can be cut to allow for below-ground pipe connections.



HB End Cap

Splay End Cap

## Accessories- Specifications

Reference	Description	Kerb Show	Length	Height (H)	Overall Width	Weight (KG)	Outlet
PK.HBGU	HB Gully Upper	75-125mm	500mm	305mm	380mm	78kg	-
PK.SGUU	Splay Gully Unit Upper	75-125mm	500mm	305mm	380mm	78kg	-
PK.GPUL	Gully Pot Unit Lower	-	375mm	750mm	375mm	3kg	160mm
PK.HBAU	Half Battered Access Units	75-100mm	250mm	360mm	215mm	19kg	160mm
PK.SAU	Splay Access Unit	75-100mm	250mm	360mm	215mm	19kg	160mm
PK.CU	Corner Units	75-100mm	250mm	305mm	220mm	18kg	-
PK.HBEC	HB End Cap	-	5mm	305mm	215mm	0.2kg	110mm
PK.SEC	Splay End Cap	-	5mm	305mm	215mm	0.2kg	110mm

## HB Gully Upper

Full batter ductile iron top and base units are a high quality and heavy-duty access/outlet. For busy highway routes, they are an ideal bind for combined kerb and drainage units as the extent of a drainage run can often be the most exposed.



HB Gully Unit Upper



Gully Pot Unit Lower

## Splay Gully Unit Upper

Splay ductile iron top and base units are a high quality and heavy-duty access/outlet. For busy highway routes, they are an ideal bind for combined kerb and drainage units as the extent of a drainage run can often be the most exposed.



Splay Gully Unit Upper



Gully Pot Unit Lower

The Gully Pot is used in conjunction with the Gully Unit Upper and is used to carry water away from the system. The Gully pot has a 160mm outlet for connecting to exterior pipes.

# MONOCHANNEL

## MonoChannel

Polycon's MonoChannel is a testament to modern engineering ingenuity, serving as a prime example of a linear surface drainage system that offers a multitude of benefits for both commercial applications. As a pioneering solution in the world of drainage systems, the MonoChannel's design epitomizes efficiency, sustainability, and safety.

One of the standout features of the MonoChannel is its linear design, providing an uninterrupted pathway for water to flow, making it exceptionally efficient in the removal of surface water and preventing flooding.

The MonoChannel stands out as a beacon of sustainability in the field. The system boasts a high recycled content, contributing to the reduction of environmental impact. Its low carbon footprint underscores Polycon's commitment to eco-conscious design, making it an ideal choice for those who prioritize sustainability.

Additionally, the MonoChannel is notably lighter in weight compared to traditional alternatives, which simplifies installation and maintenance, thereby enhancing safety while reducing labour costs. This lightweight feature is a testament to the system's innovative engineering, further underscoring its forward-thinking approach to surface drainage solutions.

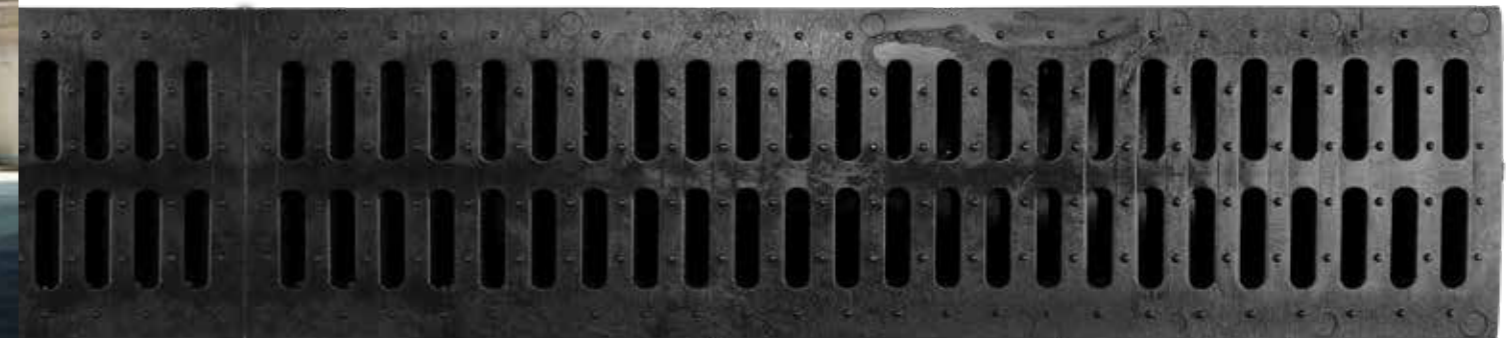

### Load Class



1.5t  
A15  
1.5 tonnes



12.5t  
B125  
12.5 tonnes



25t  
C250  
25 tonnes



40t  
D400  
40 tonnes

### Applications

- Roundabouts
- Motorways
- Highly trafficked areas
- Driveways
- Car parks
- Farms
- Commercial & civil areas
- Sports facilities

# MonoChannel - Overview

## Colour Options

Black

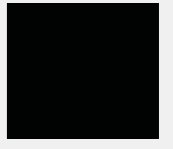

### Monolithic Design

The monolithic construction sets it apart as a reliable and hassle-free choice for addressing drainage needs in various applications, promising both functional excellence and long-lasting performance.

### Material

The MonoChannel drainage channel sets a new standard in sustainable construction by incorporating 70% recycled materials into every unit. This innovative design not only ensures efficient water management but also significantly reduces the environmental impact of the project.

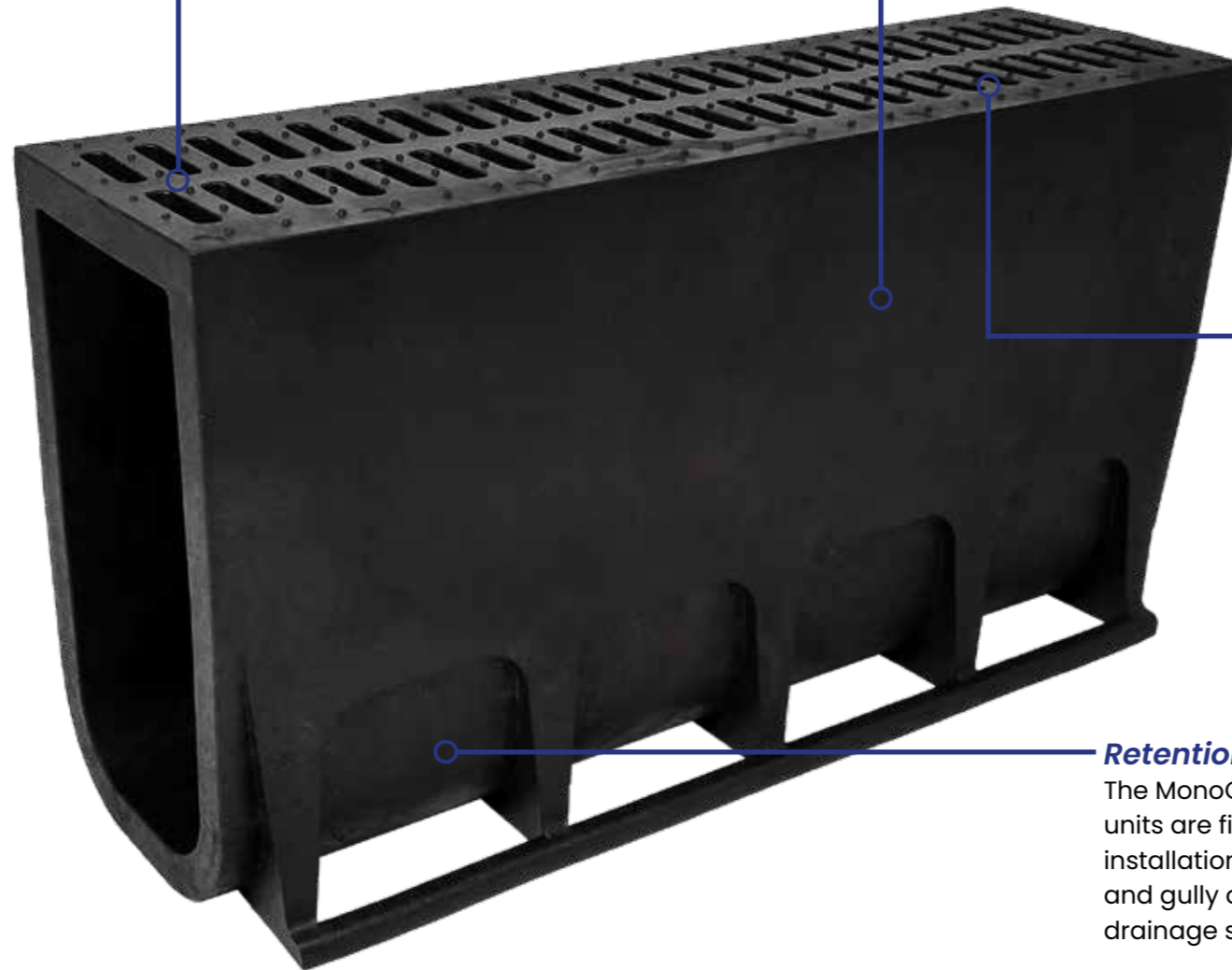

SAFEHEEL

### Retention Element

The MonoChannel has a unique retention element that ensures all units are fixed and fully integrated with the brace/bed/haunch during installation. Each section of drainage is bound by solid iron access and gully outfalls to give you a truly heavy-duty and robust surface drainage system.

## Load Classes



1.5t

A15



12.5t

B125

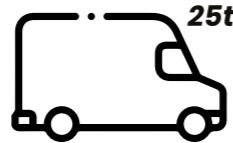

25t

C250



40t

D400

## Depth Options



160mm



260mm

# MonoChannel

MonoChannel is a cutting-edge linear surface drainage system designed to deliver a highly effective and secure means of draining a wide range of areas, including highways, car parks, and virtually any surface or structure falling within the load category spectrum, up to and including EN1433-D400.

## MonoChannel 160mm depth

The recycled & recyclable lightweight standard units are manufactured from a hydraulically efficient material and have a large useable volume.



MonoChannel 160mm depth

## MonoChannel - Specifications

Reference	Description	Length	Internal Width	Grating Width	Overall Width	Overall Depth(H1)	Internal Depth(D1)	Load Class	Safe Heel
MC.160	MonoChannel 160mm Depth	500mm	105mm	135mm	187mm	160mm	130mm	A/B/C/D	Yes
MC.260	MonoChannel 260mm Depth	500mm	105mm	135mm	187mm	260mm	220mm	A/B/C/D	Yes
MC.UECO	MonoChannel Universal End Cap Outlet	5mm	-	-	150mm	360mm	-	-	-

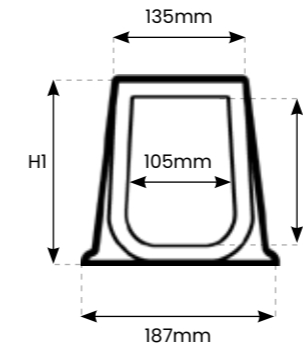

MonoChannel 160mm depth Diagram

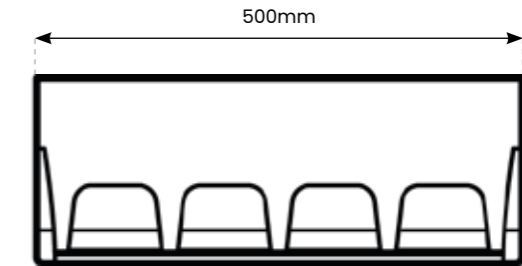

## MonoChannel 260mm depth

The recycled & recyclable lightweight standard units are manufactured from a hydraulically efficient material and have a large useable volume.



MonoChannel 260mm depth

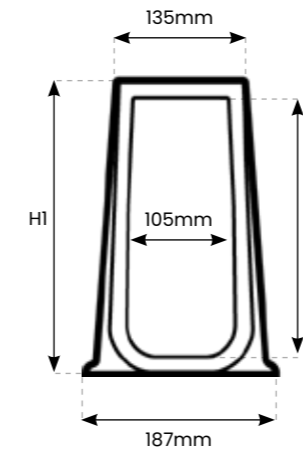

MonoChannel 260mm depth Diagram

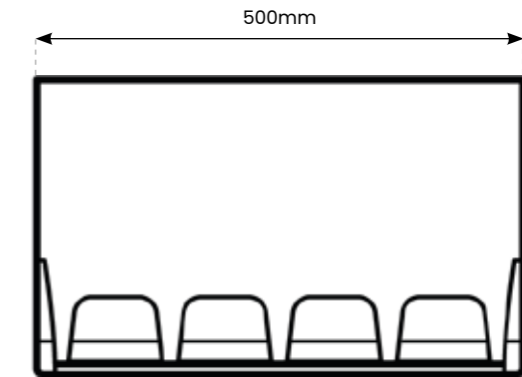

## Universal End Cap Outlet

End caps can be used at either end of the channel to stop the flow of water; they can be fitted to access/ outlets and standard units.



Universal End Cap Outlet

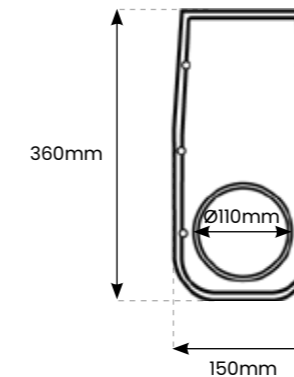

Universal End Cap Outlet Diagram

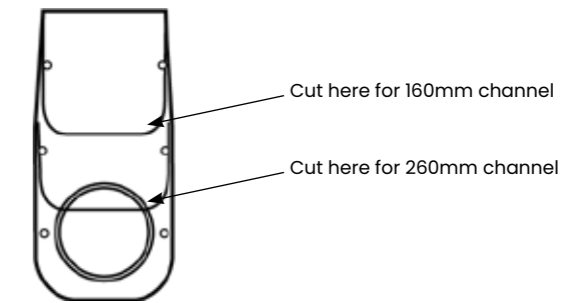

# Accessories

## Universal Outfall

The MonoChannel Universal Outfall is versatile, fitting seamlessly into channels of various depths. It offers a straightforward and spacious outlet for discharging from individual or multiple channel runs. The design ensures unrestricted flow discharge into a standard yard/road gully with a diameter of 300–375mm.



Universal Outfall

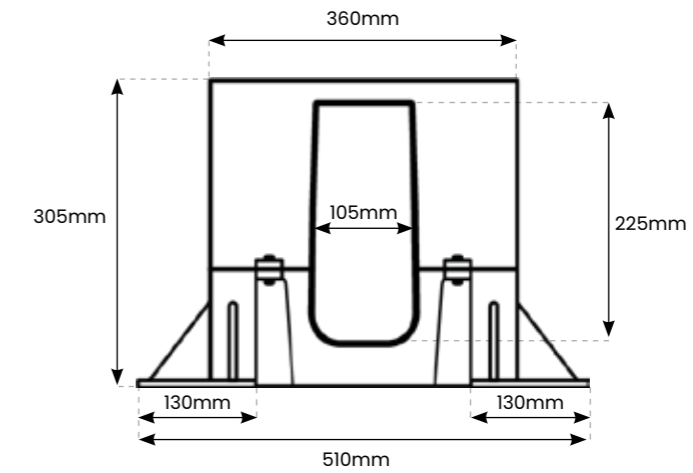

Universal Outfall Diagram

## Gully Pot

The Gully Pot is used in conjunction with the Universal Outfall and is used to carry water away from the system. The Gully pot has a 160mm outlet for connecting to exterior pipes.



Gully Pot Unit

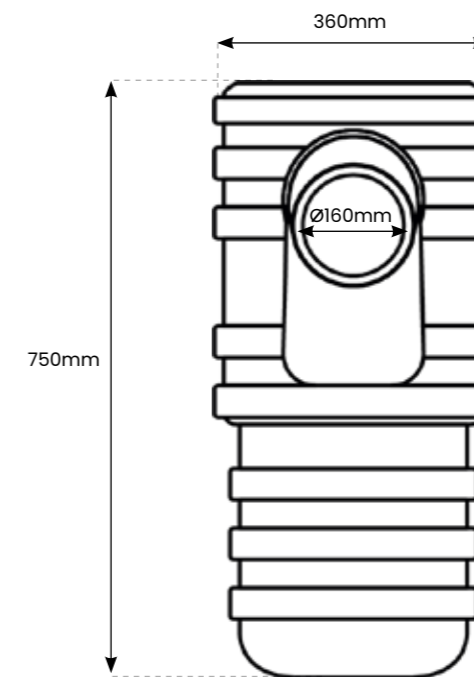

Gully Pot Diagram

## Accessories- Specifications

Reference	Description	Length	Height (H)	Grating Width	Overall Width	Weight (KG)	Outlet
MC.UO.DI	MonoChannel Universal Outfall Ductile Iron	510mm	305mm	360mm	510mm	39kg	-
MC.GPU	MonoChannel Gully Pot Unit	360mm	750mm	140mm	-	3kg	160mm

# Accessories

## Rodding Access Unit

Access points can be installed at the head of each run of the channel and at regular intervals subject to site conditions. This access unit includes a 162mm diameter outlet pipe connection.



Rodding Access Unit

## Accessories- Specifications

Reference	Description	Length	Height (H)	Grating Width	Overall Width	Weight (KG)	Outlet
MC.RAU.DI	MonoChannel Rodding Access Unit Ductile Iron	250mm	360mm	140mm	200mm	18kg	160mm
MC.SU	MonoChannel Sump Unit	500mm	450mm	-	140mm	14.8kg	110mm

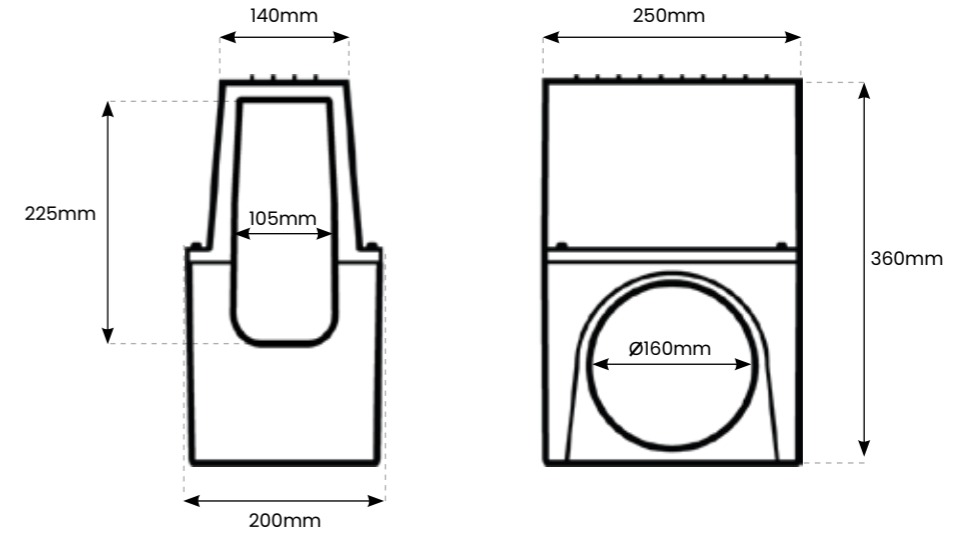

Rodding Access Unit Diagram

## Sump Unit

Sump Units act as a reservoir, temporarily storing excess water before discharging it in a controlled manner to prevent adverse effects of water accumulation. The Sump Unit is excellent for collecting debris and waste that can get into the system. It comes with a silt bucket inside for easy cleaning.



Sump Unit

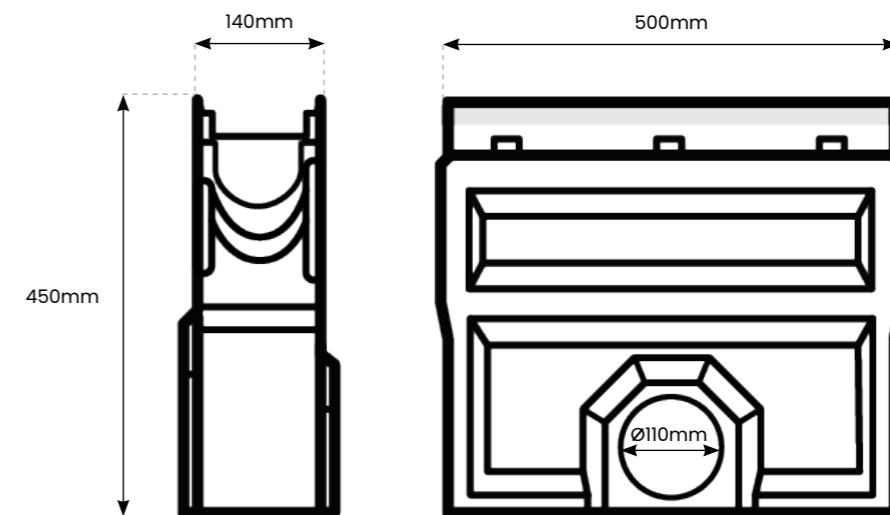

Sump Unit Diagram

# DBA

## SafetiCurb DBA

SafetiCurb Channel stands out as a long-established and well-proven linear drainage solution, offering a host of key benefits for various applications. One of its standout features is the discreet cross-fall, ingeniously designed to guide surface water effortlessly toward water inlets, ensuring effective drainage for hard-landscaped areas and roadways.

The SafetiCurb DBA slot drain is a cost-effective solution with a C250 load class, making it ideal for projects with moderate load requirements. This slot drain variant ensures durability and reliability in diverse applications.

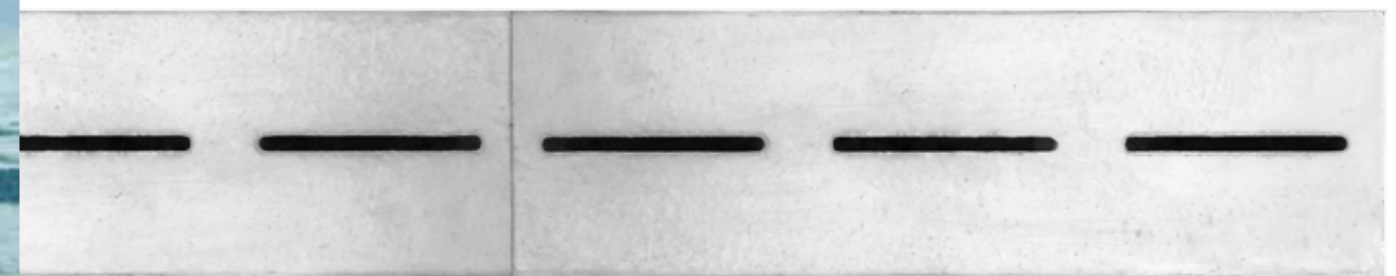

### Load Class



A15  
1.5 tonnes



B125  
12.5 tonnes

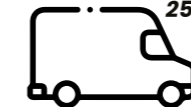

C250  
25 tonnes

### Applications

- Pathways
- Pedestrian zones
- Garage drives
- Cycle route
- Parking areas
- Service service

# SafetiCurb DBA - Overview

## Colour Options

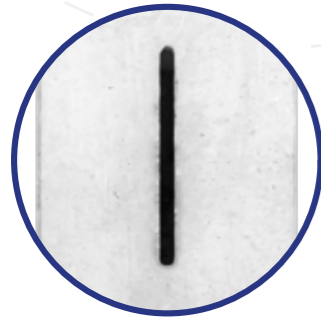
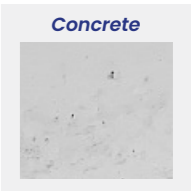

### Monolithic Design

The Safeticurb DBA showcases a monolithic design, effectively mitigating the risk of damage and enhancing the channel's overall resilience. This design features a complete absence of adhesive joints or gaps between the channel and grating, significantly reducing the potential for breakage due to harsh environmental conditions and general impacts.

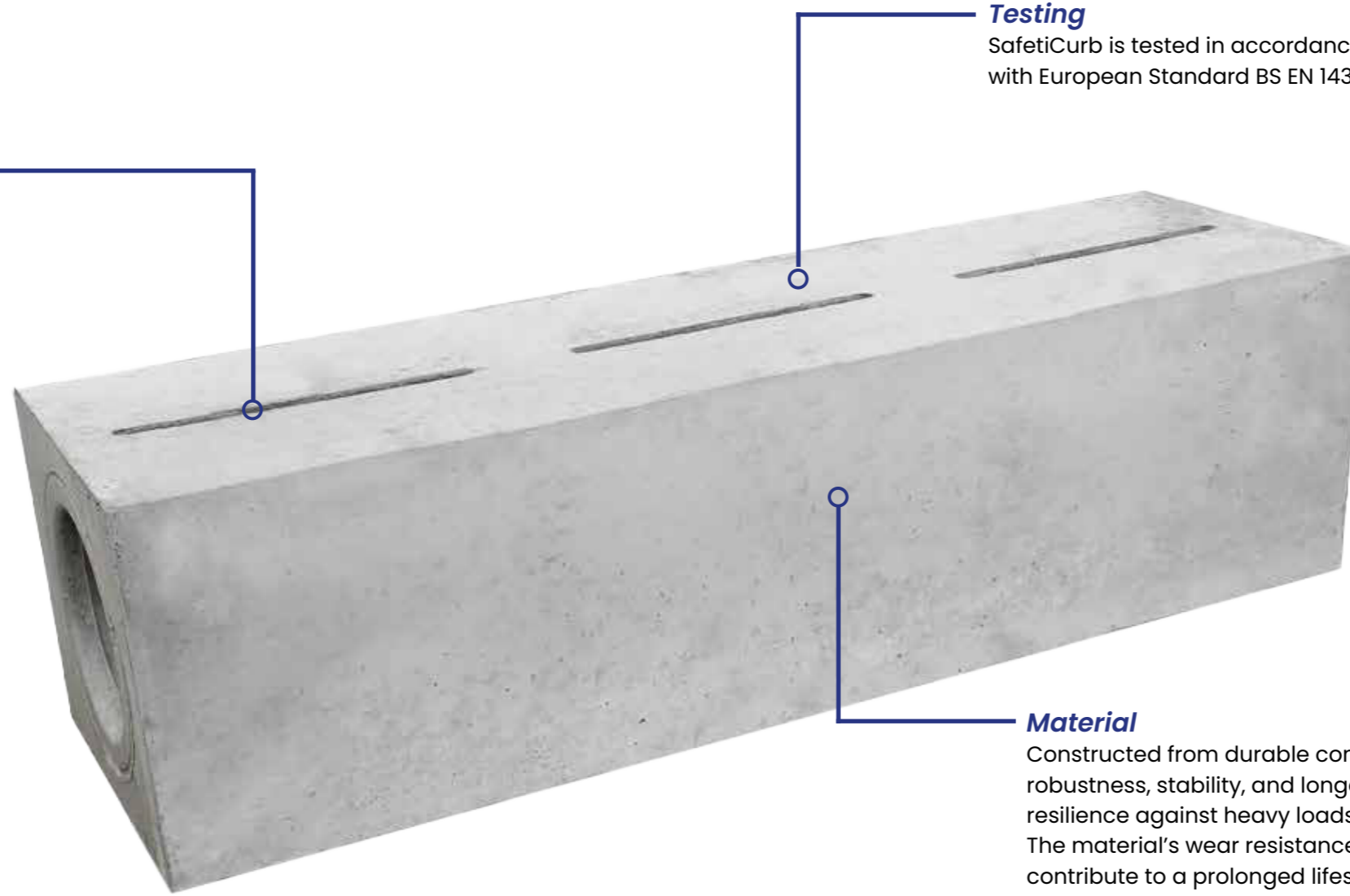

### Testing

SafetiCurb is tested in accordance with European Standard BS EN 1433.

### Material

Constructed from durable concrete, the SafetiCurb DBA offers robustness, stability, and longevity. Its inherent strength ensures resilience against heavy loads and environmental factors. The material's wear resistance and low maintenance needs contribute to a prolonged lifespan, making it a dependable and versatile solution for effective water management in diverse applications.

## Load Classes



A15

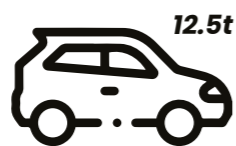

B125



C250

## Depth Options



250mm

# DBG

## SafetiCurb *DBG*

SafetiCurb Channel stands out as a long-established and well-proven linear drainage solution, offering a host of key benefits for various applications. One of its standout features is the discreet cross-fall, ingeniously designed to guide surface water effortlessly toward water inlets, ensuring effective drainage for hard-landscaped areas and roadways.

The DBG has particular emphasis on the durability and strength provided by its ductile iron grid unit. This grid unit elevates the system's load class up to D400, showcasing its exceptional robustness and capacity to handle heavy-duty applications, especially in commercial settings.

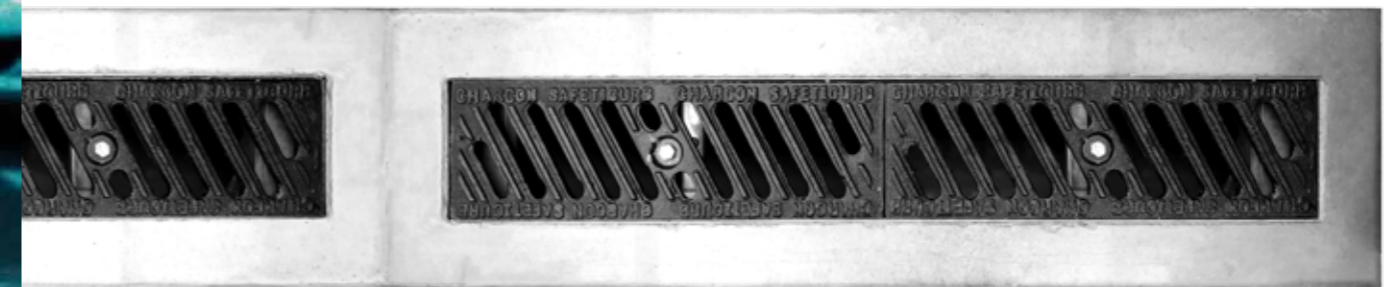

### Load Class



A15  
1.5 tonnes



B125  
12.5 tonnes



C250  
25 tonnes



D400  
40 tonnes

### Applications

- Car parks
- Pedestrian areas
- Public Highways
- Commercial & civil areas

# SafetiCurb DBG - Overview

## Colour Options



### Grating

The SafetiCurb DBG's ductile iron grating not only provides durability and high load-bearing capacity but also facilitates easy access for cleaning the channel. This accessibility is a valuable benefit, allowing for efficient maintenance and ensuring the continuous effectiveness of the drainage system.

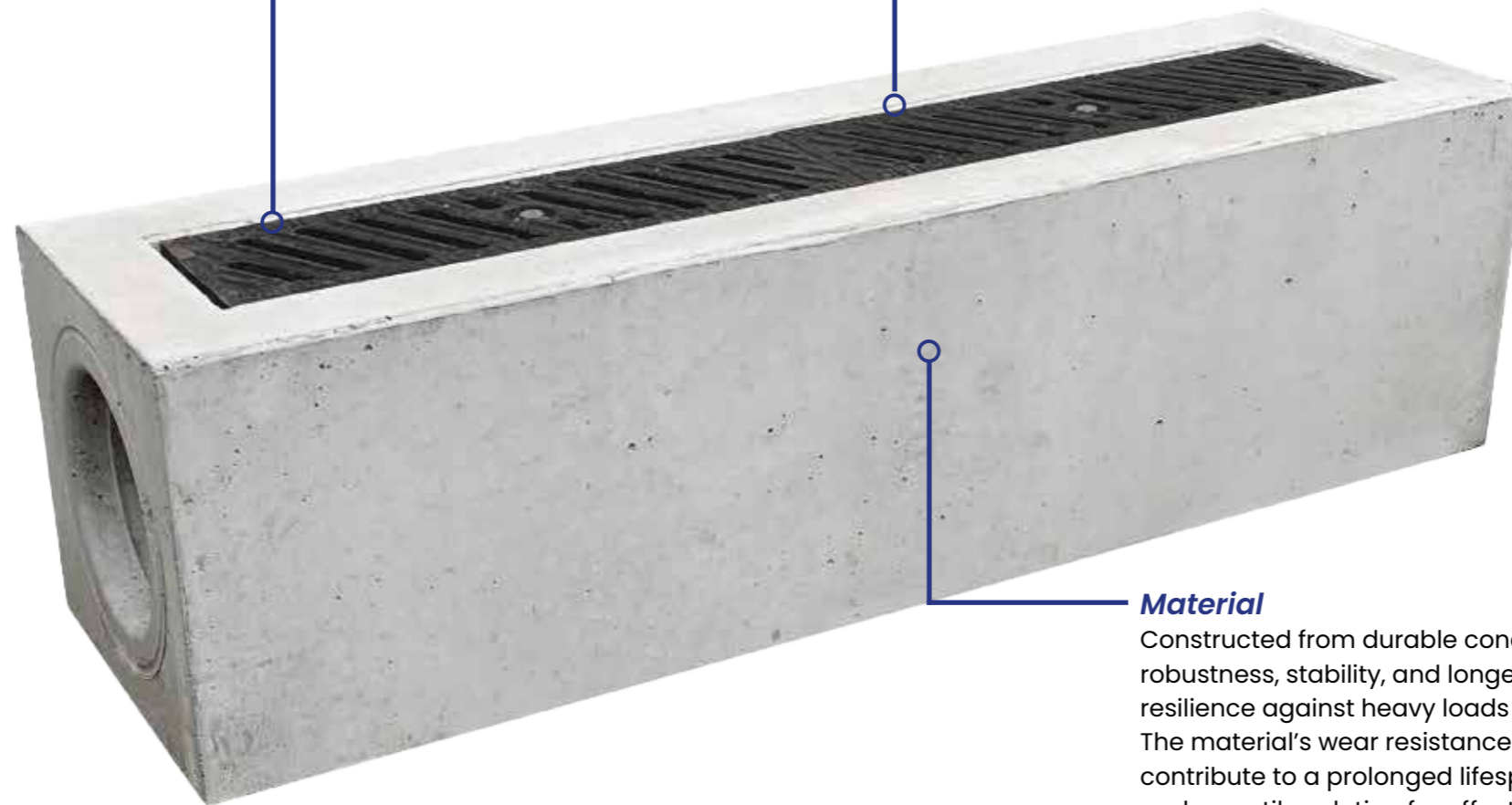

### Testing

SafetiCurb is tested in accordance with European Standard BS EN 1433.

### Material

Constructed from durable concrete, the SafetiCurb DBG offers robustness, stability, and longevity. Its inherent strength ensures resilience against heavy loads and environmental factors. The material's wear resistance and low maintenance needs contribute to a prolonged lifespan, making it a dependable and versatile solution for effective water management in diverse applications.

## Load Classes



1.5t

A15



12.5t

B125



25t

C250



40t

D400

## Depth Options



250mm

# DBM

## SafetiCurb DBM

SafetiCurb Channel stands out as a long-established and well-proven linear drainage solution, offering a host of key benefits for various applications. One of its standout features is the discreet cross-fall, ingeniously designed to guide surface water effortlessly toward water inlets, ensuring effective drainage for hard-landscaped areas and roadways.

The DBM SafetiCurb stands out for its F900 load class, making it exceptionally robust and capable of handling heavy-duty applications, such as industrial sites. This substantial reduction in the need for costly underground pipework not only enhances its economic appeal but also streamlines installation processes. Versatility is a key feature, as SafetiCurb is suitable for all hard landscape surfaces, providing a reliable and durable solution across a spectrum of projects.



### Load Class



A15  
1.5 tonnes



B125  
12.5 tonnes

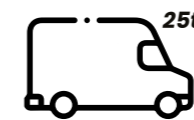

C250  
25 tonnes



D400  
40 tonnes



E600  
60 tonnes



F900  
90 tonnes

### Applications

- Car parks
- Pedestrians areas
- Public highways
- Commercial & civil areas
- Heavy duty industrial sites
- Airport taxiway

# SafetiCurb DBM - Overview

## Colour Options

Concrete

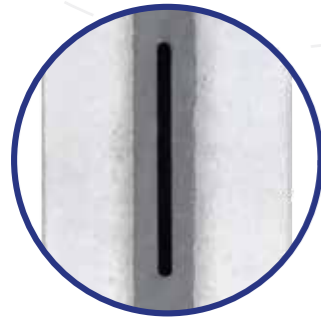
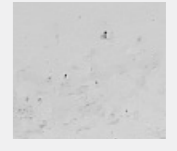

### Slot Inserts

The SafetiCurb DBM, featuring a slot reinforced with a ductile iron insert, offers noteworthy advantages in drainage design. The ductile iron insert enhances the system's strength and durability, ensuring robust performance under heavy loads.



### Testing

SafetiCurb is tested in accordance with European Standard BS EN 1433.

### Material

Constructed from durable concrete, the SafetiCurb DBM offers robustness, stability, and longevity. Its inherent strength ensures resilience against heavy loads and environmental factors. The material's wear resistance and low maintenance needs contribute to a prolonged lifespan, making it a dependable and versatile solution for effective water management in diverse applications.

## Load Classes

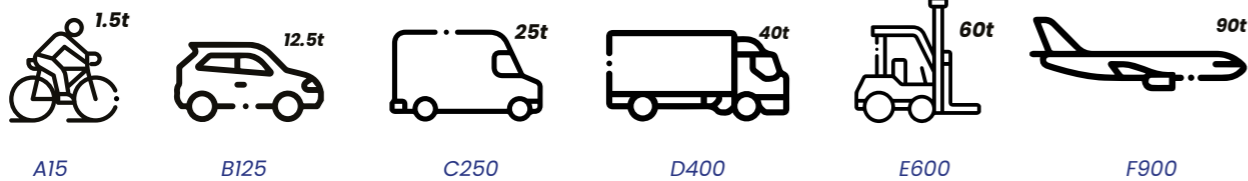

## Depth Options



250mm

# SafetiCurb DBA

Cost-effective C250 slot drain for durability and efficient water management in diverse projects, ensuring strength and efficiency with streamlined installation.

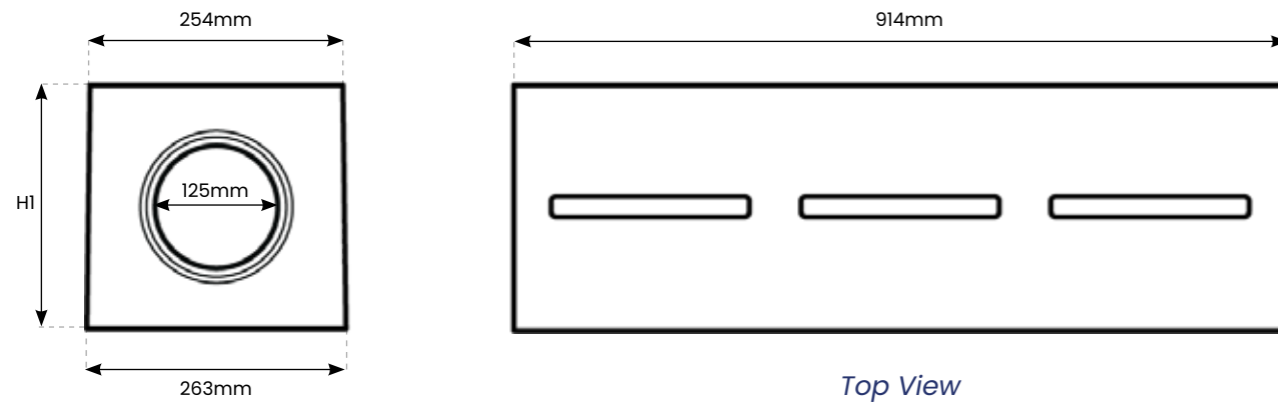

# SafetiCurb DBG

A durable and efficient 914mm with a D400 load class grid unit, offering strength and streamlined installation for diverse projects.

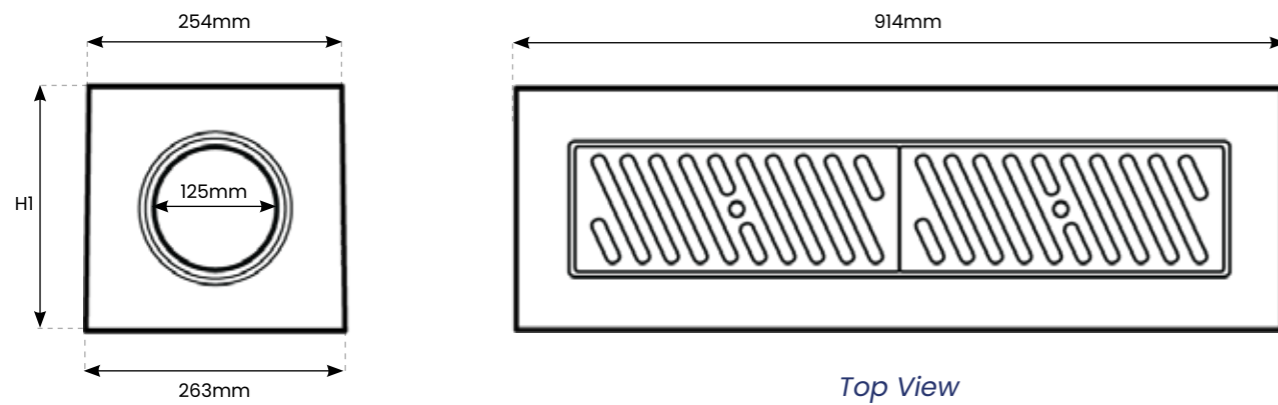

# SafetiCurb DBM

A robust 914mm slot drain with F900 load class and ductile iron insert for strength and efficiency in diverse projects.

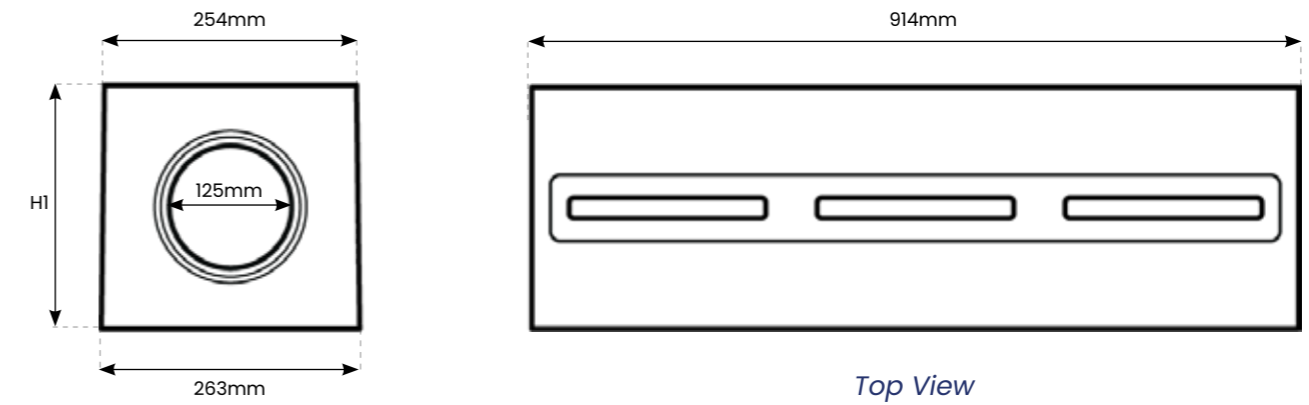

## SafetiCurb - Specifications

Reference	Description	Nominal Bore	Length	Top Width	Bottom Width	Overall Depth(H1)	Weight	Load Class
SC.DBA	SafetiCurb DBA	125mm	914mm	254mm	263mm	250mm	102kg	A/B/C
SC.DBG	SafetiCurb DBG	125mm	914mm	254mm	263mm	250mm	107kg	A/B/C/D
SC.DBM	SafetiCurb DBM	125mm	914mm	254mm	263mm	250mm	106kg	A/B/C/D/E/F

## Accessories- Specifications

Reference	Description	Nominal Bore	Length	Top Width	Bottom Width	Overall Depth(H1)	Weight	Load Class
SC.PUDH	Profile Unit DBK HB2	125mm	914mm	-	250mm	350mm	129kg	A/B/C/D
SC.TUK	Transition Unit Kerb	125mm	914mm	-	250mm	350-250mm	109kg	A/B/C/D
SC.SBTTA	Slit Box Top Type A	125mm	500mm	348mm	448mm	259mm	115kg	A/B/C
SC.SBTTH	Slit Box Top Type H	125mm	507mm	400mm	453mm	262mm	148kg	A/B/C/D/E/F
SC.MCH	Manhole Cover HB2	125mm	610mm	456mm	698mm	350mm	175kg	A/B/C/D

# Accessories

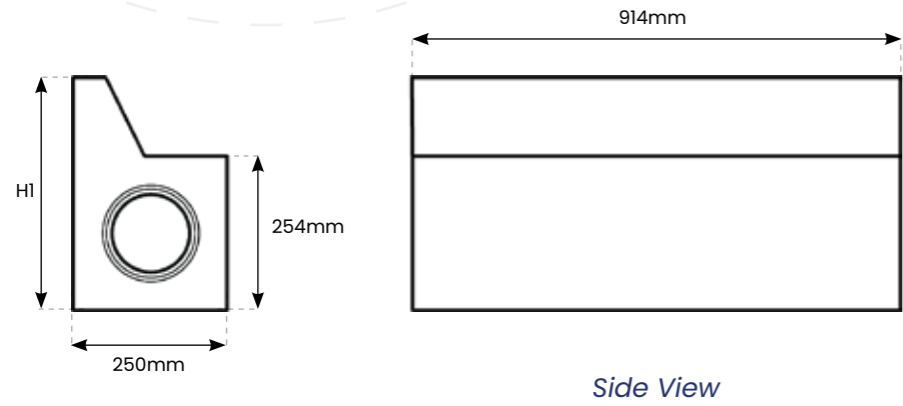

## Profile Unit DBK HB2

For use with DBK, HB2, to DBA and DBG.

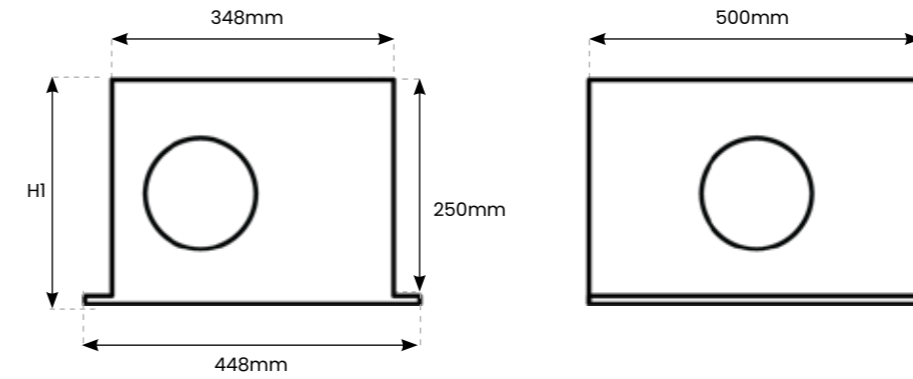

## Slit Box Top Type A

For use with DBA, DBM and DI. Supplied with Solid Top. (Ductile Iron).

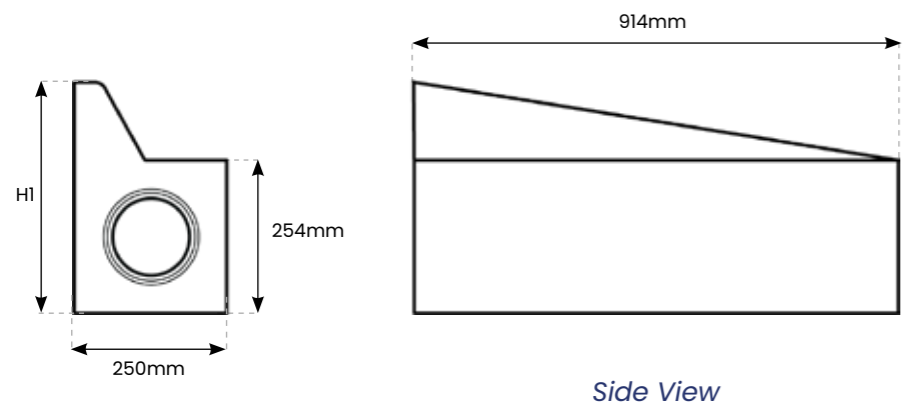

## Transition Unit Kerb

For use with DBK, HB2, to DBA and DBG.

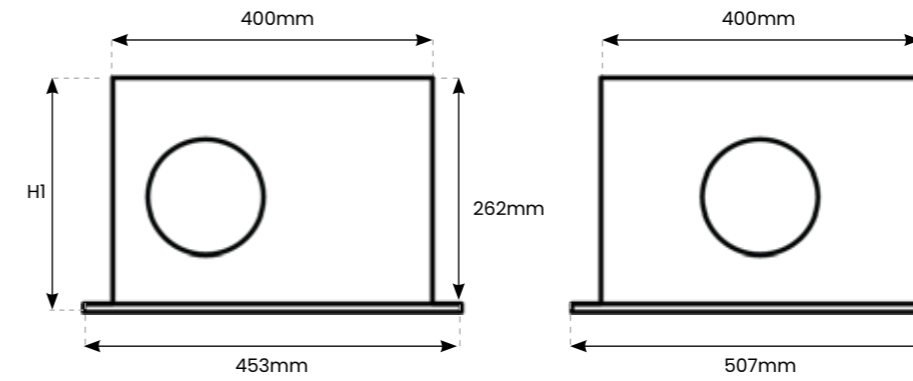

## Slit Box Top Type H

For use with DBM. Supplied with Solid Top. (Ductile Iron).

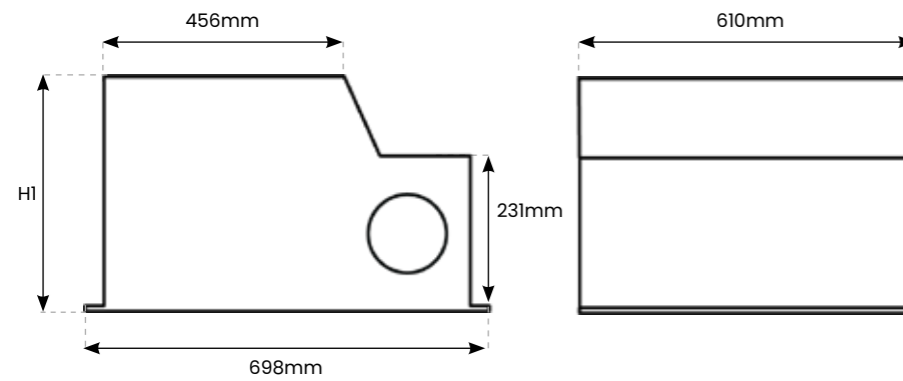

## Manhole Cover HB2

(Ductile Iron).

# MonoBlock DM1000

## MonoBlock DM1000

The MonoBlock system supplied by Polycon is a ground-breaking solution for heavy-duty load-class areas, designed to offer unparalleled stability, durability, and efficiency. At the core of its design philosophy is a one-piece monolithic unit, which sets it apart from conventional modular systems. This unique feature ensures that the entire structure is seamlessly integrated into a single, cohesive unit, eliminating the need for interlocking components, and making it ideal for a wide range of industrial and high-traffic environments.

One of the primary benefits of the Polycon MonoBlock system is its remarkable suitability for heavy-duty load class areas. The system's inherent structural strength and monolithic design make it exceptionally capable of withstanding heavy loads and intense traffic.

Durability is one of the key advantages of the MonoBlock channel as it ensures the system's longevity as well as minimising the need for frequent maintenance. Having a long lifespan and minimal maintenance means the MonoBlock system not only reduces operational costs but also leads to less disruption in high-traffic areas, enhancing overall productivity.

Furthermore, the system's efficient absorption properties enhance safety by reducing the impact of vibrations and shocks, creating a safer and more comfortable environment for both personnel and equipment. Whether in warehouse facilities, manufacturing plants, or transportation hubs, the Polycon MonoBlock system stands out as a versatile and dependable solution, perfectly suited for demanding, heavy-duty industrial settings.



### Load Class



A15  
1.5 tonnes



B125  
12.5 tonnes

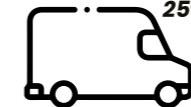

C250  
25 tonnes



D400  
40 tonnes



E600  
60 tonnes



F900  
90 tonnes

### Applications

- Industrial spaces
- Logistical centres
- Airports
- Highways
- Railways
- Parking areas
- Harbours

# MonoBlock DM1000 - Overview

## Colour Options

Stone

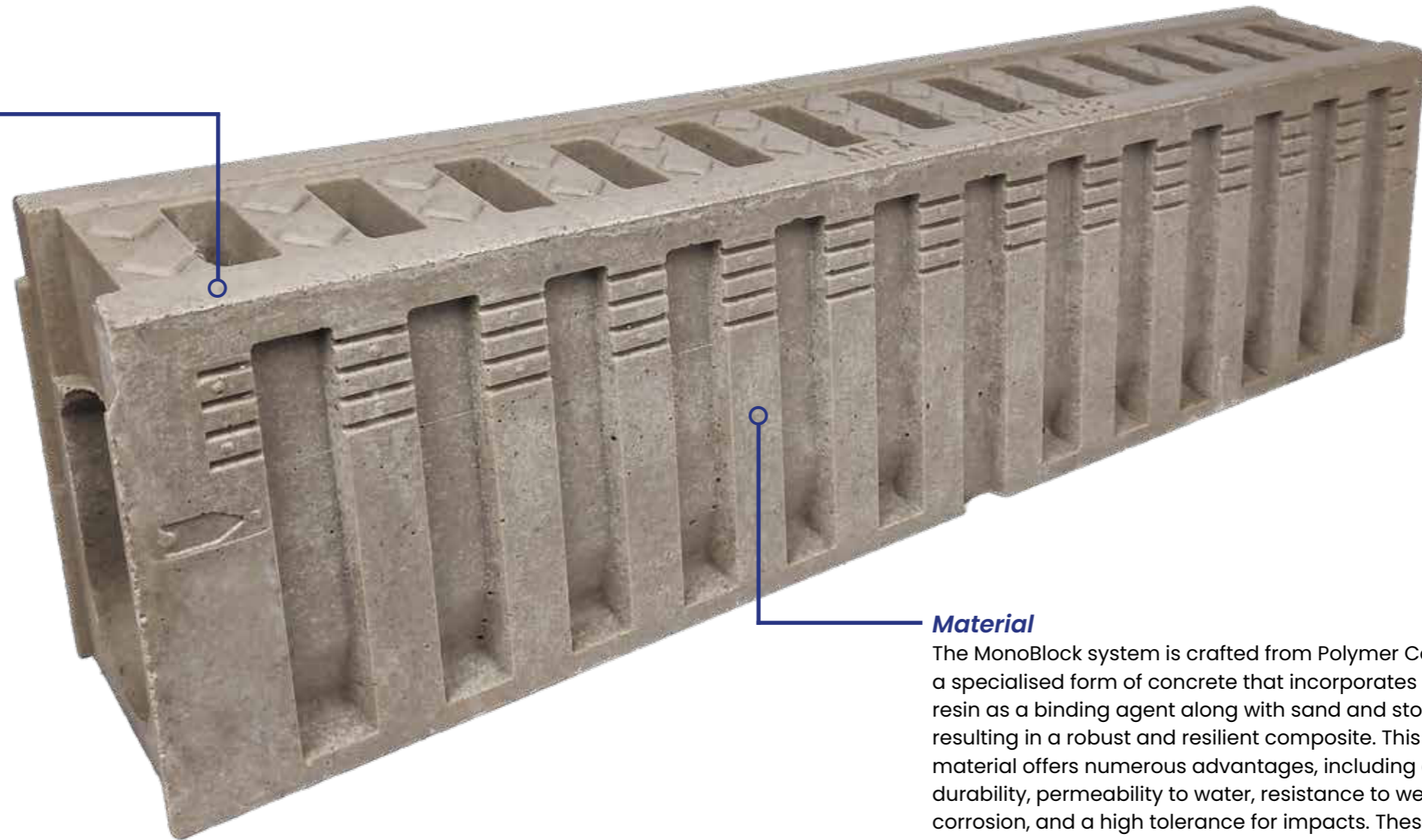

### 1-Piece Design

The MonoBlock system showcases a monolithic design, effectively mitigating the risk of damage and enhancing the channel's overall resilience. This design features a complete absence of adhesive joints or gaps between the channel and grating, significantly reducing the potential for breakage due to harsh environmental conditions and general impacts.

### Material

The MonoBlock system is crafted from Polymer Concrete, a specialised form of concrete that incorporates synthetic resin as a binding agent along with sand and stone aggregates, resulting in a robust and resilient composite. This choice of material offers numerous advantages, including exceptional durability, permeability to water, resistance to wear and corrosion, and a high tolerance for impacts. These qualities collectively make it a superb option for long-lasting installations that require minimal maintenance or repair, capable of withstanding diverse environmental conditions with ease.

## Load Classes

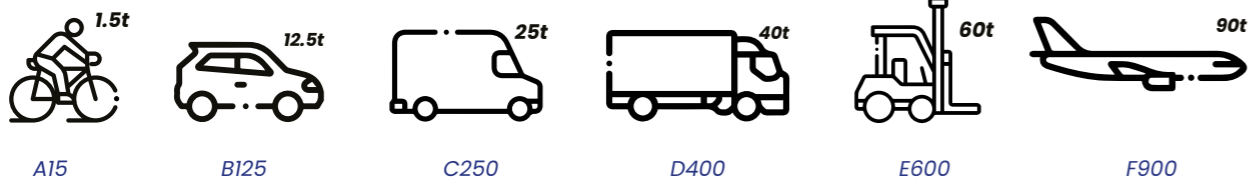

## Depth Options



265mm

# MonoBlock DM1000

The MonoBlock system is a remarkable innovation, featuring a monolithic design that eliminates the need for adhesive joints or gaps between the channel and grating, thereby enhancing its robustness and damage resistance. Crafted from Polymer Concrete, this system offers a unique blend of durability, water resistance, wear resistance, corrosion resistance, and high impact endurance, making it an ideal choice for long-term installations.

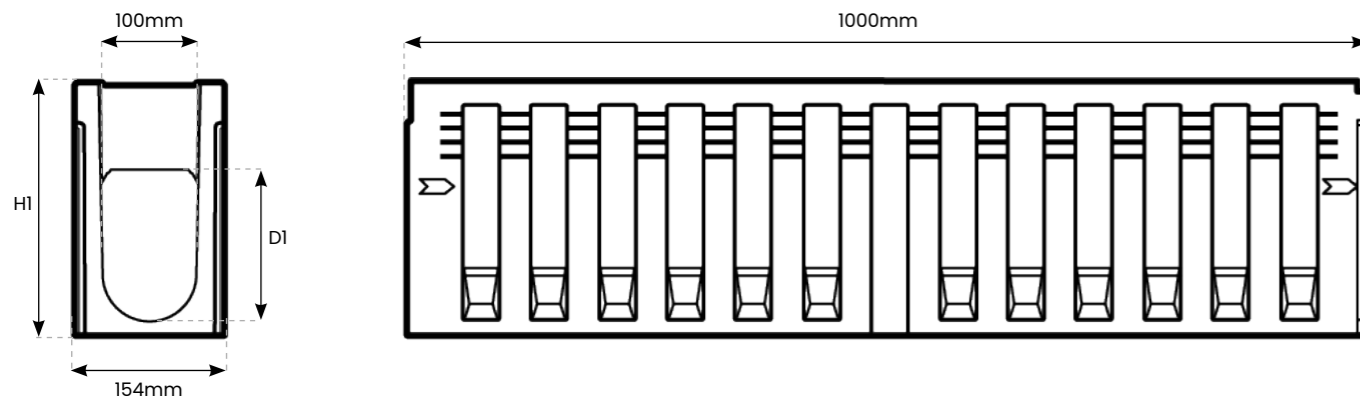

## MonoBlock DM 1000 - Specifications

Reference	Description	Pallet Quantity	Length	Internal Width	Overall Width	Overall Depth (H1)	Internal Depth (D1)	Weight	Load Class
MB.DM.1000	MonoBlock DM 1000	15	1000mm	100mm	154mm	265mm	155mm	47kg	A/B/C/D/E/F

## Accessories- Specifications

Reference	Description	Length	Height (H)	Overall Width	Weight (KG)	Outlet
MB.DM.1000.SU.DI	MonoBlock DM 1000 Sump Unit + Ductile Iron Grating	500mm	580mm	154mm	25,5kg	110mm
MB.DM.1000.AU.DI	MonoBlock DM 1000 Access Unit + Ductile Iron Grating	500mm	265mm	154mm	17,7kg	-
MB.DM.1000.EC.GS	MonoBlock DM 1000 End Cap Galvanised Steel	5mm	260mm	132mm	-	-

# Accessories

## Sump Unit

Sump Units are strategically placed at low points in the drainage channels to collect and control the flow of water, preventing flooding or water build-up in specific areas. They serve as a reservoir that temporarily stores excess water, allowing it to be efficiently redirected or drained away.



Sump Unit

## Access Unit

The MonoBlock DM 1000 access unit is equipped with features like robust covers and grates, which ensure safe and controlled access to the drainage channels. This contributes to the effective management and maintenance of channel drainage, enhancing safety and preserving infrastructure integrity.



Ductile Iron Grating (F900)

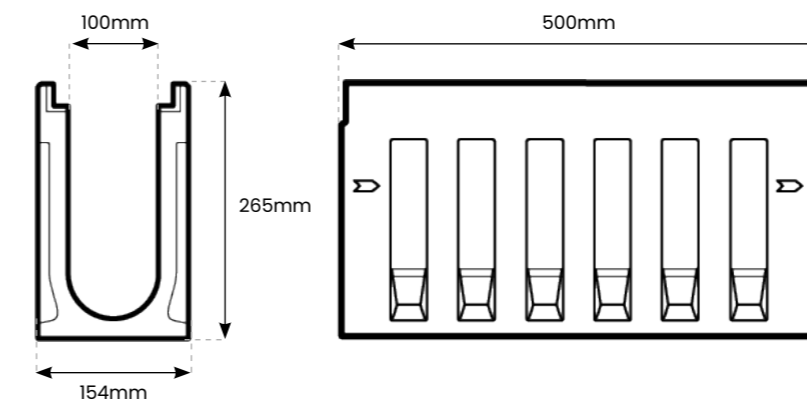

Access Unit

## End Cap

End Caps can be used at the end of your channel run to stop the flow of water.



End Cap

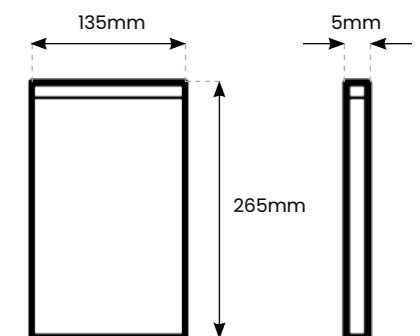

End Cap

# MonoBlock DM1500

## MonoBlock DM1500

The MonoBlock system supplied by Polycon is a ground-breaking solution for heavy-duty load-class areas, designed to offer unparalleled stability, durability, and efficiency. At the core of its design philosophy is a one-piece monolithic unit, which sets it apart from conventional modular systems. This unique feature ensures that the entire structure is seamlessly integrated into a single, cohesive unit, eliminating the need for interlocking components, and making it ideal for a wide range of industrial and high-traffic environments.

One of the primary benefits of the Polycon MonoBlock system is its remarkable suitability for heavy-duty load class areas. The system's inherent structural strength and monolithic design make it exceptionally capable of withstanding heavy loads and intense traffic.

Durability is one of the key advantages of the MonoBlock channel as it ensures the system's longevity as well as minimising the need for frequent maintenance. Having a long lifespan and minimal maintenance means the MonoBlock system not only reduces operational costs but also leads to less disruption in high-traffic areas, enhancing overall productivity.

Furthermore, the system's efficient absorption properties enhance safety by reducing the impact of vibrations and shocks, creating a safer and more comfortable environment for both personnel and equipment. Whether in warehouse facilities, manufacturing plants, or transportation hubs, the Polycon MonoBlock system stands out as a versatile and dependable solution, perfectly suited for demanding, heavy-duty industrial settings.



### Load Class



A15  
1.5 tonnes



B125  
12.5 tonnes

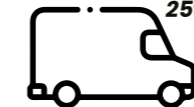

C250  
25 tonnes



D400  
40 tonnes



E600  
60 tonnes



F900  
90 tonnes

### Applications

- Industrial spaces
- Logistical centres
- Airports
- Highways
- Railways
- Parking areas
- Harbours

# MonoBlock DM1500 - Overview

## Colour Options

Stone



### 1-Piece Design

The MonoBlock system showcases a monolithic design, effectively mitigating the risk of damage and enhancing the channel's overall resilience. This design features a complete absence of adhesive joints or gaps between the channel and grating, significantly reducing the potential for breakage due to harsh environmental conditions and general impacts.

### Material

The MonoBlock system is crafted from Polymer Concrete, a specialised form of concrete that incorporates synthetic resin as a binding agent along with sand and stone aggregates, resulting in a robust and resilient composite. This choice of material offers numerous advantages, including exceptional durability, permeability to water, resistance to wear and corrosion, and a high tolerance for impacts. These qualities collectively make it a superb option for long-lasting installations that require minimal maintenance or repair, capable of withstanding diverse environmental conditions with ease.

## Load Classes

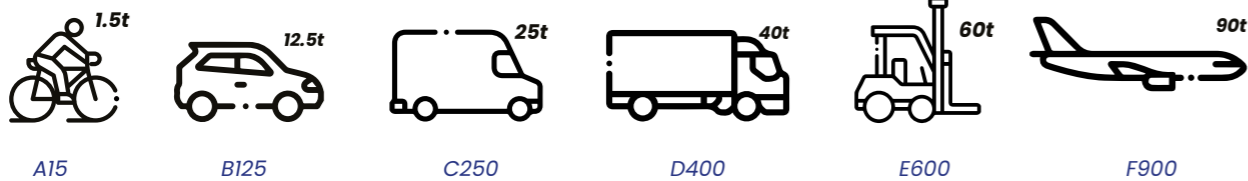

## Depth Options



280mm

# MonoBlock DM1500

The MonoBlock system is a remarkable innovation, featuring a monolithic design that eliminates the need for adhesive joints or gaps between the channel and grating, thereby enhancing its robustness and damage resistance. Crafted from Polymer Concrete, this system offers a unique blend of durability, water resistance, wear resistance, corrosion resistance, and high impact endurance, making it an ideal choice for long-term installations.

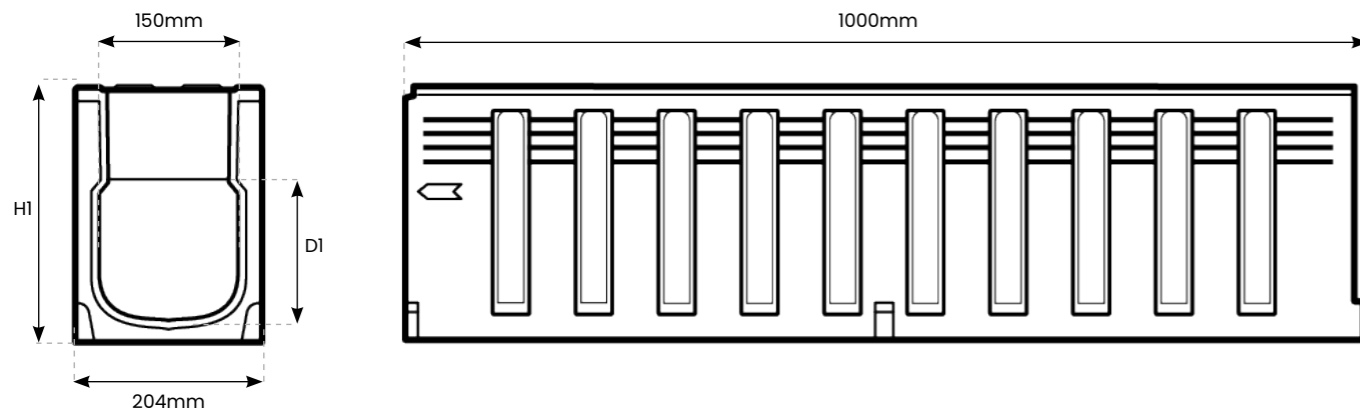

## MonoBlock DM 1500 - Specifications

Reference	Description	Pallet Quantity	Length	Internal Width	Overall Width	Overall Depth (H1)	Internal Depth (D1)	Weight	Load Class
MB.DM.1500	MonoBlock DM 1500	12	1000mm	150mm	204mm	280mm	160mm	63kg	A/B/C/D/E/F

## Accessories- Specifications

Reference	Description	Length	Height (H)	Overall Width	Outlet
MB.DM.1500.SU.UP.DI	MonoBlock DM 1500 Sump Unit Upper Part + Ductile Iron Grating	500mm	280mm	204mm	-
MB.DM.1500.SU.LP.DI	MonoBlock DM 1500 Sump Unit Lower Part + Ductile Iron Grating	524mm	390mm	344mm	-
MB.DM.1500.SU.160.DI	MonoBlock DM 1500 Sump Unit Lower Part + 160 Ø + Ductile Iron Grating	524mm	335mm	495mm	160mm
MB.DM.1500.SU.200.DI	MonoBlock DM 1500 Sump Unit Lower Part + 200 Ø + Ductile Iron Grating	524mm	335mm	495mm	200mm
MB.DM.1500.AU.DI	MonoBlock DM 1500 Access Unit + Ductile Iron Grating	500mm	528mm	305mm	-
MB.DM.1500.EC.GS	MonoBlock DM 1500 End Cap Galvanised Steel	5mm	280mm	200mm	-

# Accessories

## Sump Unit

Sump Units are strategically placed at low points in the drainage channels to collect and control the flow of water, preventing flooding or water build-up in specific areas. They serve as a reservoir that temporarily stores excess water, allowing it to be efficiently redirected or drained away.

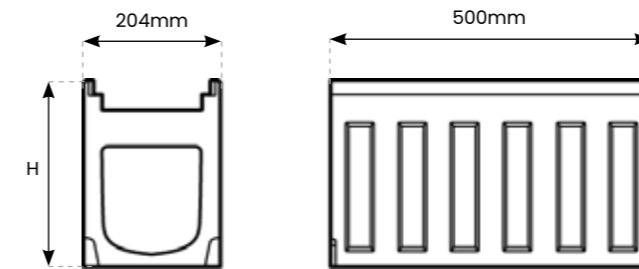

Sump Unit - Upper Part

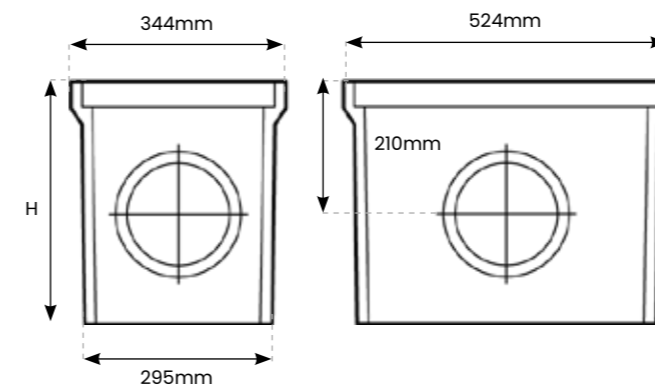

Sump Unit - Lower Part

\*\* Sump Unit - Lower Part is available with 160 Ø and 200 Ø outlets.

## Access Unit

The MonoBlock DM 1500 access unit is equipped with features like robust covers and grates, which ensure safe and controlled access to the drainage channels. This contributes to the effective management and maintenance of channel drainage, enhancing safety and preserving infrastructure integrity.

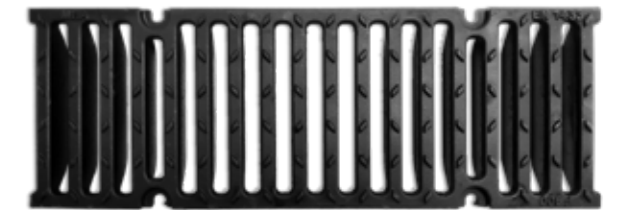

Ductile Iron Grating (F900)

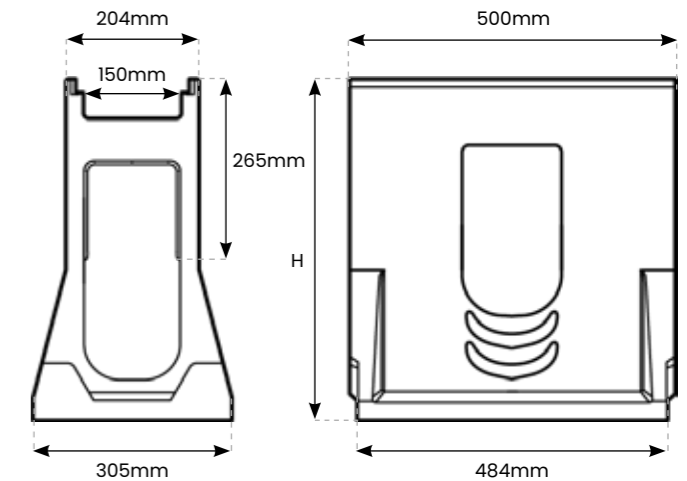

Access Unit

## End Cap

End Caps can be used at the end of your channel run to stop the flow of water.



End Cap

# MonoBlock DM2000

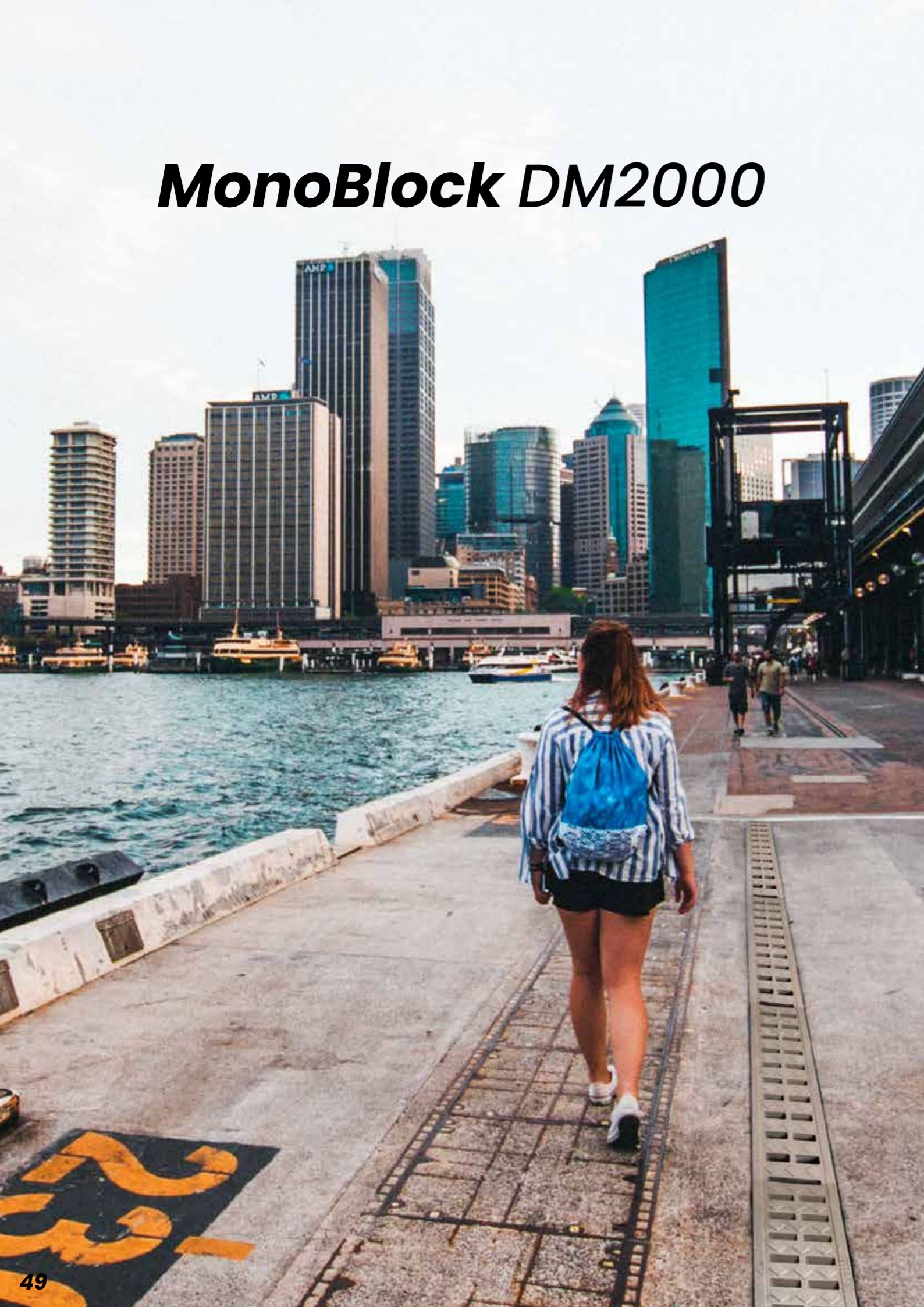

## MonoBlock DM2000

The MonoBlock system supplied by Polycon is a ground-breaking solution for heavy-duty load-class areas, designed to offer unparalleled stability, durability, and efficiency. At the core of its design philosophy is a one-piece monolithic unit, which sets it apart from conventional modular systems. This unique feature ensures that the entire structure is seamlessly integrated into a single, cohesive unit, eliminating the need for interlocking components, and making it ideal for a wide range of industrial and high-traffic environments.

One of the primary benefits of the Polycon MonoBlock system is its remarkable suitability for heavy-duty load class areas. The system's inherent structural strength and monolithic design make it exceptionally capable of withstanding heavy loads and intense traffic.

Durability is one of the key advantages of the MonoBlock channel as it ensures the system's longevity as well as minimising the need for frequent maintenance. Having a long lifespan and minimal maintenance means the MonoBlock system not only reduces operational costs but also leads to less disruption in high-traffic areas, enhancing overall productivity.

Furthermore, the system's efficient absorption properties enhance the safety of the channel by reducing the impact of vibrations and shocks, creating a safer and more comfortable environment for both personnel and equipment. Whether in warehouse facilities, manufacturing plants, or transportation hubs, the Polycon MonoBlock system stands out as a versatile and dependable solution, perfectly suited for demanding, heavy-duty industrial settings.



### Load Class



A15  
1.5 tonnes



B125  
12.5 tonnes

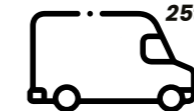

C250  
25 tonnes



D400  
40 tonnes



E600  
60 tonnes



F900  
90 tonnes

### Applications

- Industrial spaces
- Logistical centres
- Airports
- Highways
- Railways
- Parking areas
- Harbours

# MonoBlock DM2000 - Overview

## Colour Options

Stone



### 1-Piece Design

The MonoBlock system showcases a monolithic design, effectively mitigating the risk of damage and enhancing the channel's overall resilience. This design features a complete absence of adhesive joints or gaps between the channel and grating, significantly reducing the potential for breakage due to harsh environmental conditions and general impacts.

### Material

The MonoBlock system is crafted from Polymer Concrete, a specialised form of concrete that incorporates synthetic resin as a binding agent along with sand and stone aggregates, resulting in a robust and resilient composite. This choice of material offers numerous advantages, including exceptional durability, permeability to water, resistance to wear and corrosion, and a high tolerance for impacts. These qualities collectively make it a superb option for long-lasting installations that require minimal maintenance or repair, capable of withstanding diverse environmental conditions with ease.

## Load Classes

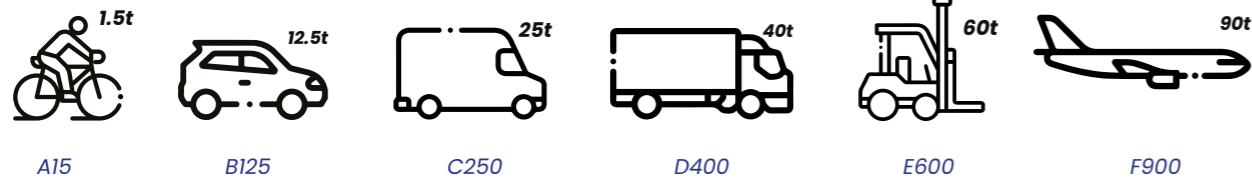

## Depth Options

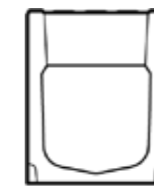

320mm

# MonoBlock DM2000

The MonoBlock system is a remarkable innovation, featuring a monolithic design that eliminates the need for adhesive joints or gaps between the channel and grating, thereby enhancing its robustness and damage resistance. Crafted from Polymer Concrete, this system offers a unique blend of durability, water resistance, wear resistance, corrosion resistance, and high impact endurance, making it an ideal choice for long-term installations.

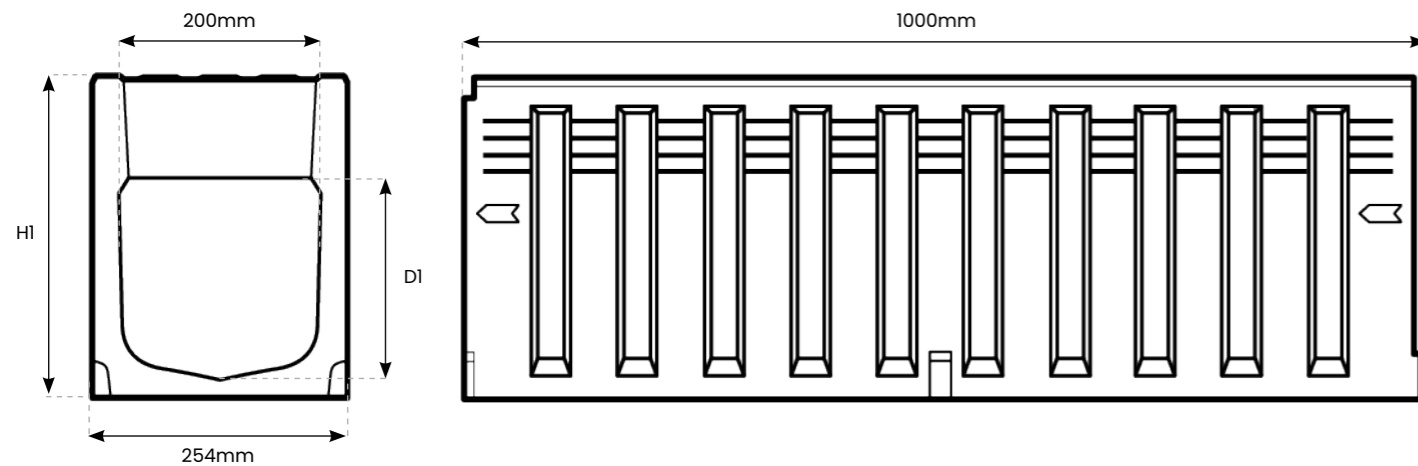

## MonoBlock DM 2000 - Specifications

Reference	Description	Pallet Quantity	Length	Internal Width	Overall Width	Overall Depth(HI)	Internal Depth(DI)	Weight	Load Class
MB.DM.2000	MonoBlock DM 2000	9	1000mm	200mm	254mm	320mm	200mm	79kg	A/B/C/D/E/F

## Accessories- Specifications

Reference	Description	Length	Height (H)	Overall Width	Outlet
MB.DM.2000.SU.UP.320.DI	MonoBlock DM 2000 Sump Unit Upper Part 320 Depth + Ductile Iron Grating	500mm	320mm	304mm	-
MB.DM.2000.SU.UP.465.DI	MonoBlock DM 2000 Sump Unit Upper Part 465 Depth + Ductile Iron Grating	500mm	320mm	304mm	-
MB.DM.2000.SU.UP.615.DI	MonoBlock DM 2000 Sump Unit Upper Part 615 Depth + Ductile Iron Grating	500mm	320mm	304mm	-
MB.DM.2000.SU.LP.DI	MonoBlock DM 2000 Sump Unit Lower Part + Ductile Iron Grating	524mm	390mm	344mm	-
MB.DM.2000.SU.160.DI	MonoBlock DM 2000 Sump Unit Lower Part + 160 Ø + Ductile Iron Grating	524mm	335mm	495mm	160mm
MB.DM.2000.SU.200.DI	MonoBlock DM 2000 Sump Unit Lower Part + 200 Ø + Ductile Iron Grating	524mm	335mm	495mm	200mm
MB.DM.2000.SU.350.DI	MonoBlock DM 2000 Sump Unit Lower Part 350 Depth + Ductile Iron Grating	524mm	350mm	344mm	-
MB.DM.2000.SU.500.DI	MonoBlock DM 2000 Sump Unit Lower Part 500 Depth + Ductile Iron Grating	524mm	500mm	344mm	-
MB.DM.2000.AU.320.DI	MonoBlock DM 2000 Access Unit 320 Depth + Ductile Iron Grating	500mm	320mm	304mm	-
MB.DM.2000.AU.320.200.DI	MonoBlock DM 2000 Access Unit 320 Depth + 200 Ø + Ductile Iron Grating	500mm	500mm	304mm	200mm
MB.DM.2000.AU.420.DI	MonoBlock DM 2000 Access Unit 420 Depth + Ductile Iron Grating	500mm	420mm	304mm	-
MB.DM.2000.AU.615.DI	MonoBlock DM 2000 Access Unit 615 Depth + Ductile Iron Grating	500mm	615mm	304mm	-

# Accessories

## Sump Unit

Sump Units are strategically placed at low points in the drainage channels to collect and control the flow of water, preventing flooding or water build-up in specific areas. They serve as a reservoir that temporarily stores excess water, allowing it to be efficiently redirected or drained away.

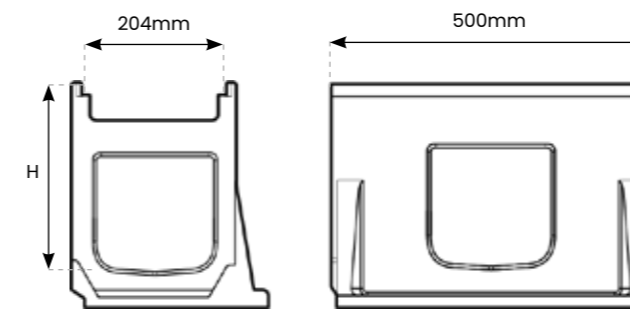

\*\* Sump Unit - Upper Part is available in 3 depths: 320, 465, 615mm.

### Sump Unit - Upper Part

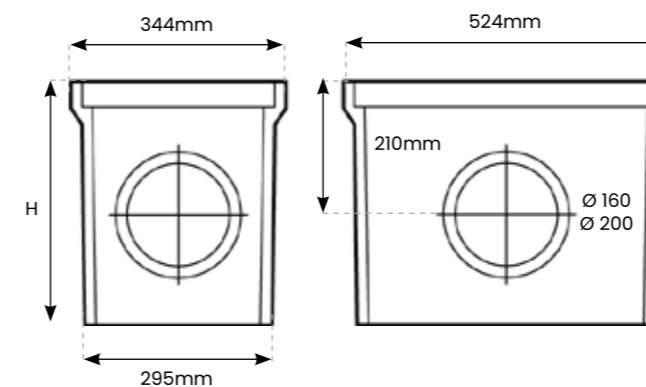

\*\* Sump Unit - Lower Part is available with 160 Ø and 200 Ø outlets.

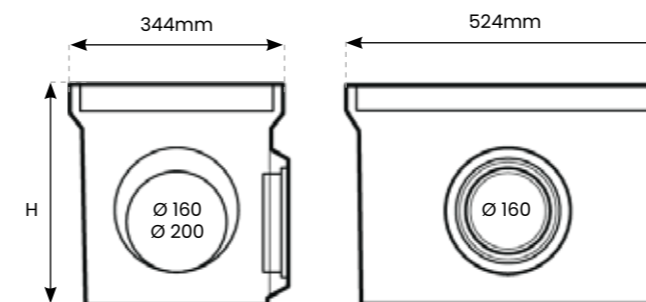

\*\* Sump Unit - Lower Part is available in 2 depths 350mm and 500mm.

### Sump Unit - Lower Part

## Access Unit

The MonoBlock DM 2000 access unit is equipped with features like robust covers and grates, which ensures safe and controlled access to the drainage channels. This contributes to the effective management and maintenance of channel drainage, enhancing safety and preserving infrastructure integrity.



Ductile Iron Grating (F900)

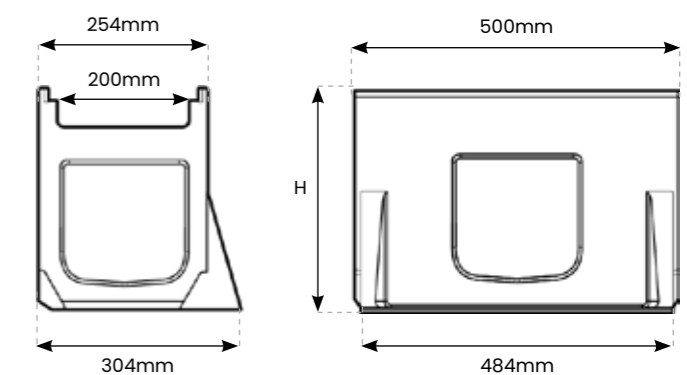

\*\* Access Unit is available in 3 depths and with the bottom 200 Ø outlet.

### Access Unit

## End Cap

End Caps can be used at the end of your channel run to stop the flow of water.



End Cap



**Polycon Surface Water Drainage**

**Widnes Business Park  
Foundry Lane  
Widnes  
Cheshire  
WA8 8UB**

**[www.polycon.co.uk](http://www.polycon.co.uk)  
0151 422 9747  
[sales@polycon.co.uk](mailto:sales@polycon.co.uk)**

*Service . Range . Knowledge*