



MonoBlock DM1500

Service . Range . Knowledge

Welcome To Polycon

Polycon is identified as one of the leading manufacturers, distributors, and suppliers of channel drainage in the UK. We focus towards creating a diverse range of water solutions, in a variety of different materials, including composite, polymer concrete, SMC, and steel.

Polycon's unique look at the market and expert knowledge of the industry ensures that we can supply a wide range of high-quality products suitable for any application. This includes building drainage, landscaping, sports facilities, distribution centres, highways, and airports.

Our design team provides innovative and efficient hydraulic solutions to ensure we can offer the best product/ solution for your drainage needs. We have a vast and experienced overview of our working industry and have been manufacturing, distributing, and selling channel drainage for over 8 years. We thrive on acting upon your feedback to improve and develop our products to fit flawlessly with the constantly changing market and demand from our customers.

At Polycon we focus our attention on professionals who sit within the construction industry, targeting our products to specifiers, architects, engineers, and contractors. Therefore, we understand the importance of expanding our product portfolio to create the most efficient surface water drainage systems.

We are a dynamic and evolving company with a focus on quality, innovation, and service. As a result, you can rely on us to handle your project needs in every way to the best of our ability.

Contents

<i>MonoBlock DM1500</i>	3
<i>MonoBlock DM1500 Overview</i>	5
<i>MonoBlock DM1500 Specifications</i>	7
<i>Accessories</i>	8
<i>Installation Guide</i>	9

MonoBlock DM1500

The MonoBlock system supplied by Polycon is a ground-breaking solution for heavy-duty load-class areas, designed to offer unparalleled stability, durability, and efficiency. At the core of its design philosophy is a one-piece monolithic unit, which sets it apart from conventional modular systems. This unique feature ensures that the entire structure is seamlessly integrated into a single, cohesive unit, eliminating the need for interlocking components, and making it ideal for a wide range of industrial and high-traffic environments.

One of the primary benefits of the Polycon MonoBlock system is its remarkable suitability for heavy-duty load class areas. The system's inherent structural strength and monolithic design make it exceptionally capable of withstanding heavy loads and intense traffic.

Durability is one of the key advantages of the MonoBlock channel as it ensures the system's longevity as well as minimising the need for frequent maintenance. Having a long lifespan and minimal maintenance means the MonoBlock system not only reduces operational costs but also leads to less disruption in high-traffic areas, enhancing overall productivity.

Furthermore, the system's efficient absorption properties enhance safety by reducing the impact of vibrations and shocks, creating a safer and more comfortable environment for both personnel and equipment. Whether in warehouse facilities, manufacturing plants, or transportation hubs, the Polycon MonoBlock system stands out as a versatile and dependable solution, perfectly suited for demanding, heavy-duty industrial settings.



Load Class

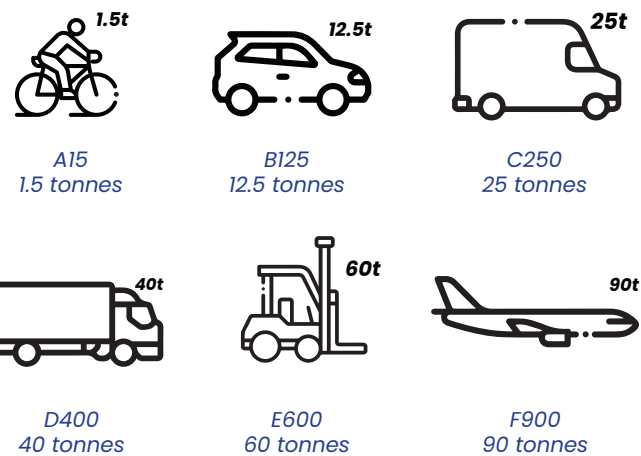

Applications

- Industrial spaces
- Logistical centres
- Airports
- Highways
- Railways
- Parking areas
- Harbours

MonoBlock DM1500



MonoBlock DM1500 - Overview

Colour Options

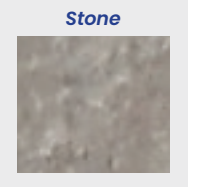

1-Piece Design

The MonoBlock system showcases a monolithic design, effectively mitigating the risk of damage and enhancing the channel's overall resilience. This design features a complete absence of adhesive joints or gaps between the channel and grating, significantly reducing the potential for breakage due to harsh environmental conditions and general impacts.

Material

The MonoBlock system is crafted from Polymer Concrete, a specialised form of concrete that incorporates synthetic resin as a binding agent along with sand and stone aggregates, resulting in a robust and resilient composite. This choice of material offers numerous advantages, including exceptional durability, permeability to water, resistance to wear and corrosion, and a high tolerance for impacts. These qualities collectively make it a superb option for long-lasting installations that require minimal maintenance or repair, capable of withstanding diverse environmental conditions with ease.

Load Classes

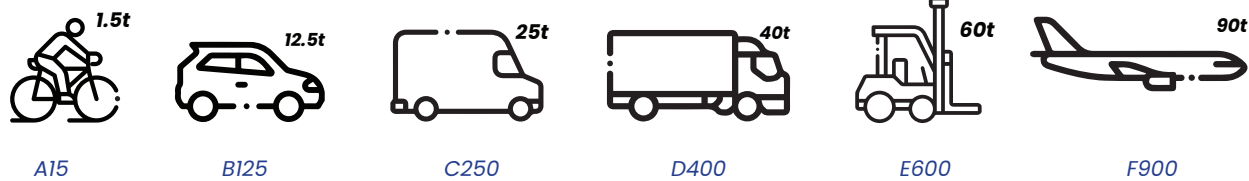

Depth Options

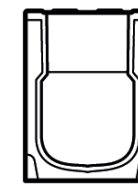

280mm

MonoBlock DM1500

The MonoBlock system is a remarkable innovation, featuring a monolithic design that eliminates the need for adhesive joints or gaps between the channel and grating, thereby enhancing its robustness and damage resistance. Crafted from Polymer Concrete, this system offers a unique blend of durability, water resistance, wear resistance, corrosion resistance, and high impact endurance, making it an ideal choice for long-term installations.

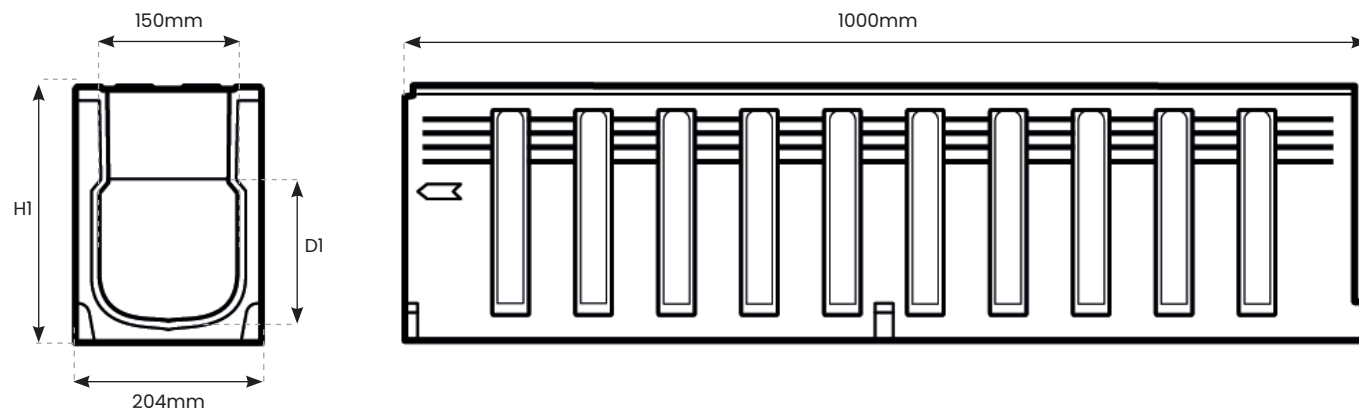

MonoBlock DM 1500 - Specifications

Reference	Description	Pallet Quantity	Length	Internal Width	Overall Width	Overall Depth (H1)	Internal Depth (D1)	Load Class
MB.DM.1500	MonoBlock DM 1500	12	1000mm	150mm	204mm	280mm	160mm	A/B/C/D/E/F

Accessories- Specifications

Reference	Description	Length	Height (H)	Overall Width	Outlet
MB.DM.1500.SU.UP.DI	MonoBlock DM 1500 Sump Unit Upper Part + Ductile Iron Grating	500mm	280mm	204mm	-
MB.DM.1500.SU.LP.DI	MonoBlock DM 1500 Sump Unit Lower Part + Ductile Iron Grating	524mm	390mm	344mm	-
MB.DM.1500.SU.160.DI	MonoBlock DM 1500 Sump Unit Lower Part + 160 Ø + Ductile Iron Grating	524mm	335mm	495mm	160mm
MB.DM.1500.SU.200.DI	MonoBlock DM 1500 Sump Unit Lower Part + 200 Ø + Ductile Iron Grating	524mm	335mm	495mm	200mm
MB.DM.1500.AU.DI	MonoBlock DM 1500 Access Unit + Ductile Iron Grating	500mm	528mm	305mm	-
MB.DM.1500.EC.GS	MonoBlock DM 1500 End Cap Galvanised Steel	5mm	280mm	200mm	-

Accessories

Sump Unit

Sump Units are strategically placed at low points in the drainage channels to collect and control the flow of water, preventing flooding or water build-up in specific areas. They serve as a reservoir that temporarily stores excess water, allowing it to be efficiently redirected or drained away.

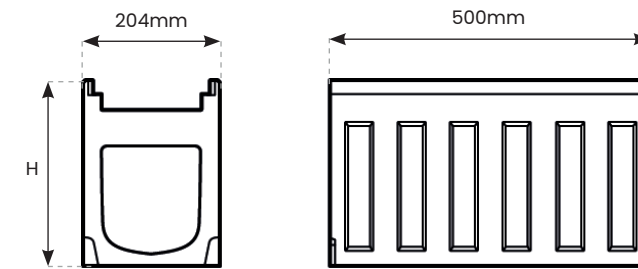

Sump Unit - Upper Part

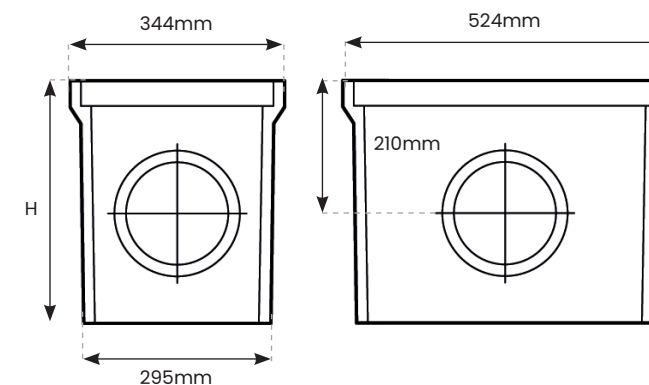

Sump Unit - Lower Part

** Sump Unit - Lower Part is available with 160 Ø and 200 Ø outlets.

Access Unit

The MonoBlock DM 1500 access unit is equipped with features like robust covers and grates, which ensure safe and controlled access to the drainage channels. This contributes to the effective management and maintenance of channel drainage, enhancing safety and preserving infrastructure integrity.

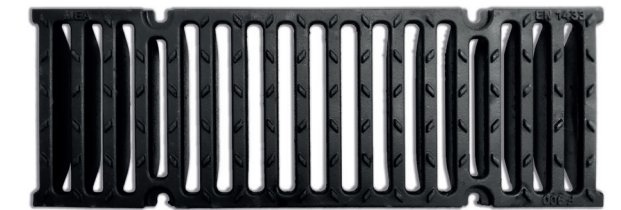

Ductile Iron Grating (F900)

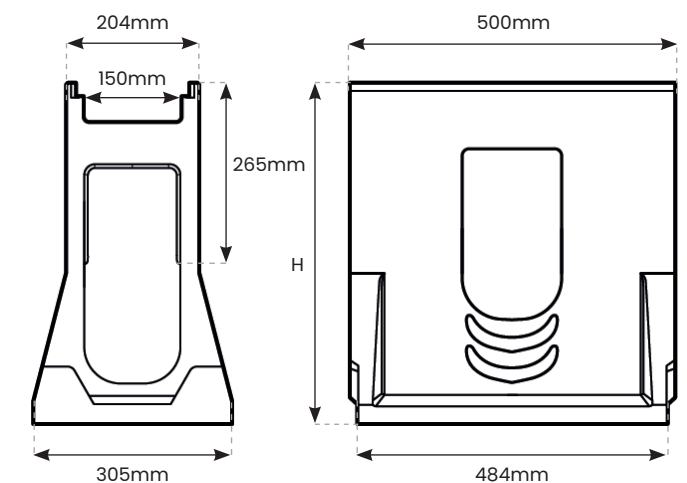

Access Unit

End Cap

End Caps can be used at the end of your channel run to stop the flow of water.



End Cap

Installation Guide

Asphalt

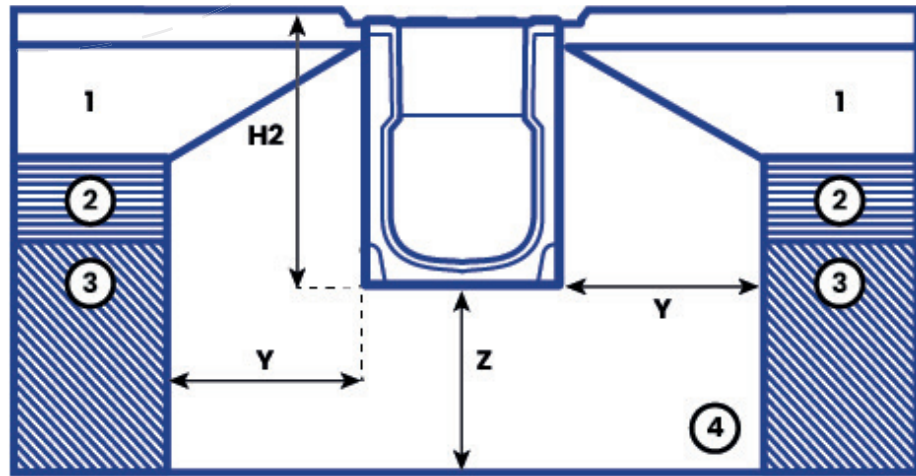

Concrete

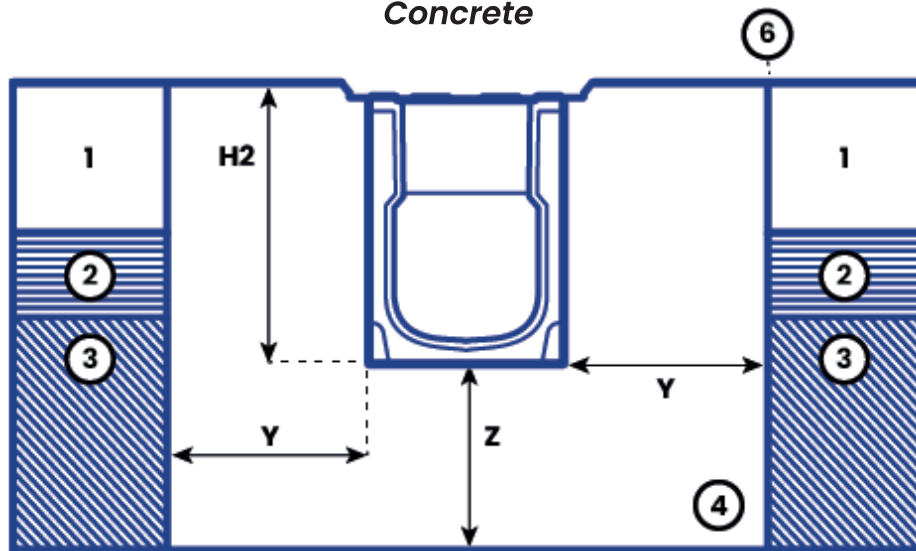

Block Paving

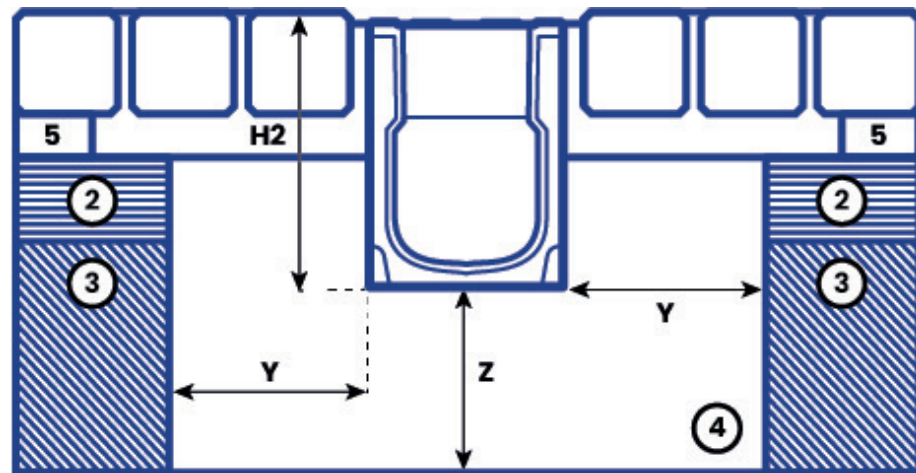

Ground conditions must be suitable and all dimensions shown are the minimum requirement. Engineering advice should be taken where necessary and any questions should be directed to Polycon's technical team by emailing us at sales@polycon.co.uk or by calling us on **0151 424 9747**.

1	2	3	4	5	6
Concrete	Sub Base	Earth	Concrete Haunch	Sand Layer	Expansion Joint

Dowel Bar Installation

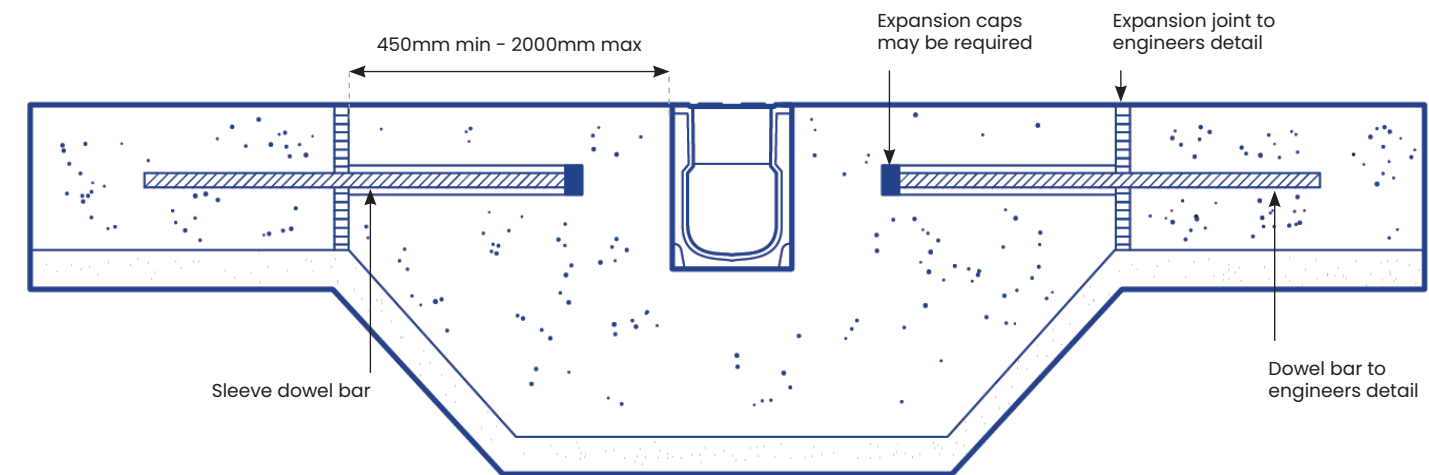

Load Class	A15	B125	C250	D400	E600	F900
H2 - Channel Height	Channel Height	Channel Height	Channel Height	Channel Height	Channel Height	Channel Height
Y - Minimum Surround	100mm	150mm	150mm	200mm	200mm	200mm
Z - Minimum Surround	100mm	150mm	150mm	200mm	200mm	200mm
T1 - Minimum Depth	40mm	40mm	40mm	40mm	40mm	40mm
T2 - Maximum Depth	95mm	55mm	55mm	55mm	55mm	55mm

** Minimum Concrete Haunch 25 N/mm².
Detail A allow for overbuild of 3mm to 5mm above the grating surfaces.



Polycon Surface Water Drainage

**Widnes Business Park
Foundry Lane
Widnes
Cheshire
WA8 8UB**

**www.polycon.co.uk
0151 422 9747
sales@polycon.co.uk**

Service . Range . Knowledge