

KE - 100

*Galvanised Edge Channel /
Stainless Steel Edge Channel*

Channel Drainage

A15 to E600 loading

Level Invert or Sloped

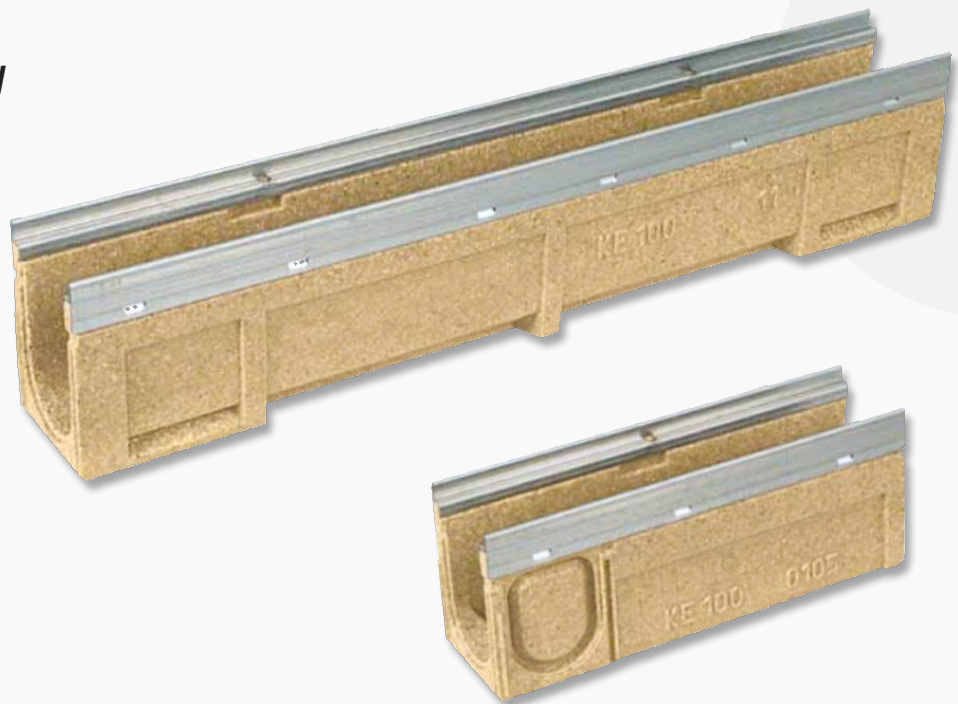

KE - 100

Technical Data Sheet



Stepped, Level, Sloped

Area drainage with channel runs is normally made according to 3 different principles. The slops of water surface is achieved by the natural fall of the land. The water flows downwards with the gradient of the water level. A stepped invert is realised by an artificial gradient which is formed by the installation of stepped-height channels and connectors. The high flow rate with self-cleaning effect can be achieved with channels in natural slope. All slope types can be combined according to hydraulic requirements and topographical conditions.

Stepped Invert

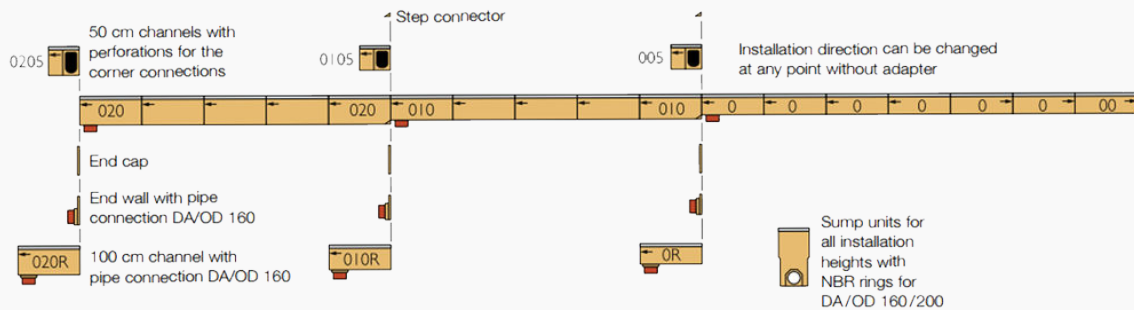

Level Invert

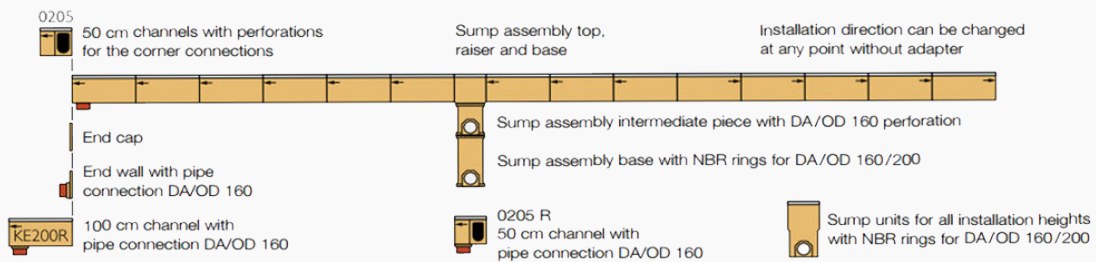

Sloped Invert

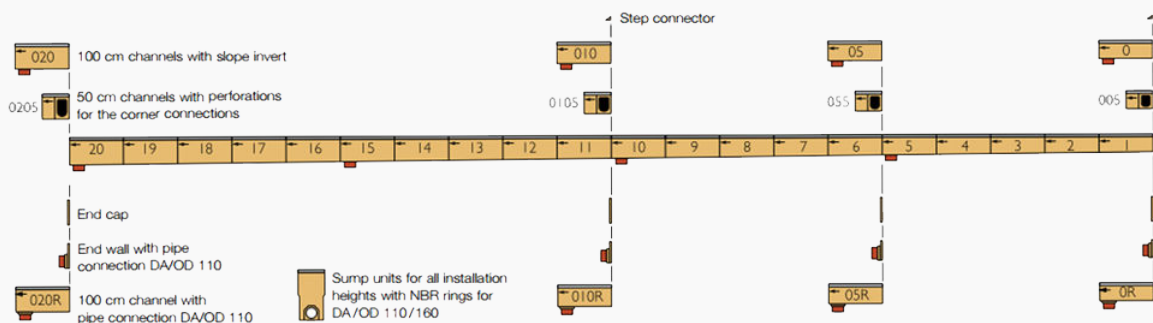

KE - 100

Technical Data Sheet

KE - 100

Galvanised Steel / Stainless Steel edge rail

- The KE-100 system consists of drainage channels for vehicular and pedestrian areas. The KE-100 channels correspond to multiple cover gratings which are assigned specific loads classes depending on their use.

Also available in **black cataphoretic** dip coating

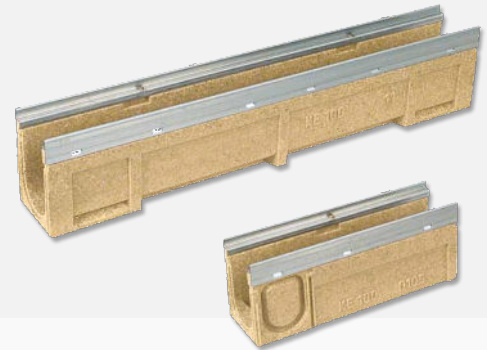

Measurements

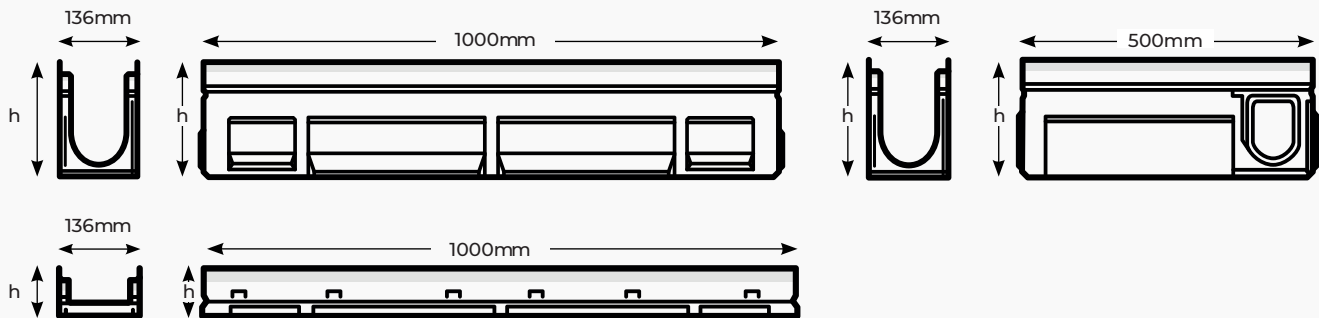

Channel / Component body

Polymere concrete:	Polyester resin-based with mineral aggregates, additives
Compressive strength:	> 90 N/mm ²
Bending tensile strength:	> 22 N/mm ²
Modulus of elasticity:	ca. 25 kN/mm ²
Density:	2.1 - 2.3 g/dm ³
Heat resistance:	100°C (permenant loading)
Frost resistance:	-50°C
Water penetration depth:	0mm
Water absorption	0.05%
Edge protection:	Galvanised steel, stainless steel, profile thickness 6mm or cataphoretic black
Channel cover:	Galvanised steel, V2A stainless steel, GJS cast-iron, PA plastic

KE - 100

Technical Data Sheet



KE - 100

Channel Types *Galvanised Steel / Stainless Steel edge rail*

Article no.	Designation	Slope %	Length cm	Width cm	Height (h)cm	Weight kg
KE.100.0	KE - 100 Channel No. 0*	0	100	13.9	15	17.5
KE.100.0R	KE - 100 Channel No. 0R***	0	100	13.9	15	17.5
KE.100.005	KE - 100 Channel No. 005**/*	0	50	13.9	15	9.5
KE.100.1	KE - 100 Channel No. 1	0.5	100	13.9	15.5	17.5
KE.100.2	KE - 100 Channel No. 2	0.5	100	13.9	16	17.5
KE.100.3	KE - 100 Channel No. 3	0.5	100	13.9	16.5	18
KE.100.4	KE - 100 Channel No. 4	0.5	100	13.9	17	18
KE.100.5	KE - 100 Channel No. 5*	0.5	100	13.9	17.5	18.5
KE.100.05	KE - 100 Channel No. 05*	0	100	13.9	17.5	18.5
KE.100.05R	KE - 100 Channel No. 05R***	0	100	13.9	17.5	18.5
KE.100.055	KE - 100 Channel No. 055**/*	0	50	13.9	17.5	9.5
KE.100.6	KE - 100 Channel No. 6	0.5	100	13.9	18	19
KE.100.7	KE - 100 Channel No. 7	0.5	100	13.9	18.5	19.5
KE.100.8	KE - 100 Channel No. 8	0.5	100	13.9	19	19.5
KE.100.9	KE - 100 Channel No. 9	0.5	100	13.9	19.5	20
KE.100.10	KE - 100 Channel No. 10*	0.5	100	13.9	20	21
KE.100.010	KE - 100 Channel No. 010*	0	100	13.9	20	21
KE.100.010R	KE - 100 Channel No. 010R***	0	100	13.9	20	21
KE.100.0105	KE - 100 Channel No. 0105**/*	0	50	13.9	20	10.5
KE.100.11	KE - 100 Channel No. 11	0.5	100	13.9	20.5	20.5
KE.100.12	KE - 100 Channel No. 12	0.5	100	13.9	21	21
KE.100.13	KE - 100 Channel No. 13	0.5	100	13.9	21.5	21.5
KE.100.14	KE - 100 Channel No. 14	0.5	100	13.9	21.5	22
KE.100.15	KE - 100 Channel No. 15*	0.5	100	13.9	22	22.5
KE.100.16	KE - 100 Channel No. 16	0.5	100	13.9	22.5	23
KE.100.17	KE - 100 Channel No. 17	0.5	100	13.9	23	23
KE.100.18	KE - 100 Channel No. 18	0.5	100	13.9	23.5	23.5
KE.100.19	KE - 100 Channel No. 19	0.5	100	13.9	24	24
KE.100.20	KE - 100 Channel No. 20*	0.5	100	13.9	24.5	24.5
KE.100.020	KE - 100 Channel No. 020*	0	100	13.9	25	25.5
KE.100.020R	KE - 100 Channel No. 020R***	0	100	13.9	25	25.5
KE.100.0205	KE - 100 Channel No. 0205**/*	0	50	13.9	25	11.2
KE.100.060	KE - 100 Channel No. 060*	0	100	13.9	6	13.1
KE.100.060R	KE - 100 Channel No. 060R***	0	100	13.9	6	13.1
KE.100.080	KE - 100 Channel No. 080*	0	100	13.9	8	13.3
KE.100.080R	KE - 100 Channel No. 080R***	0	100	13.9	8	13.3
KE.100.0100	KE - 100 Channel No. 0100*	0	100	13.9	10	14.4
KE.100.0100R	KE - 100 Channel No. 0100R*	0	100	13.9	10	14.4

* Channel with mouldings for vertical outlet DA/OD 110

** Channel with sidewise perforations for the connection of t-junctions, elbow joints and cross-over joints and vertical outlet

*** Channel with vertical pipe socket DA/OD 110

KE - 100

Technical Data Sheet

KE - 100

Sump & Accessories

- The **KE - 100** system has a complete range of accessories including a **Sump Unit & Galvanised bucket** which can collect silt particles and has **110mm** and **160mm** outlets for pipe connections
- The system also has **end caps** and **end cap outlets** with a **110mm** pipe connector

Also available in **black cataphoretic** dip coating

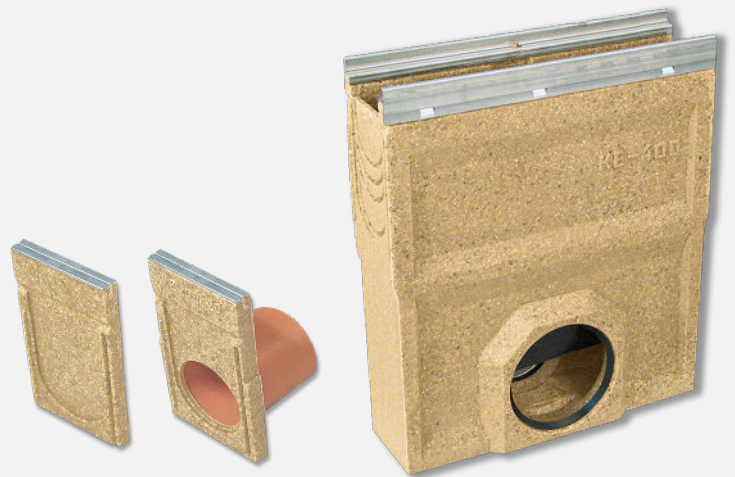

Measurements

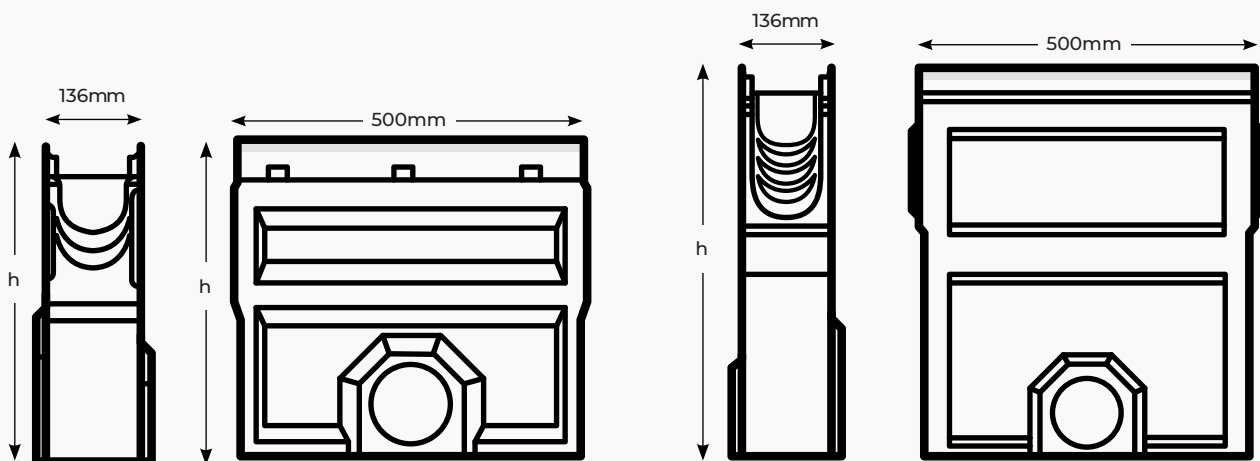

KE - 100

Technical Data Sheet



KE - 100

Accessories

Article no.	Designation	Length cm	Width cm	Height (h)cm	Weight kg
KE.100.SG	KE - 100 Sump unit with galvanised mud bucket	50	13.6	58.5	38.5
KE.100.S.10	KE - 100 Sump unit low height for channels up to No.10	50	13.6	45	21.8
KE.100.S.DN110	KE - 100 Sump unit low height with special DN 110 connection & PE bucket	50	13.6	45	21.9
KE.100.P.110	Pipe socket DA/OD 110				0.2
KE.100.P.150	Pipe socket DA/OD 150				0.6
KE.100.CE.0205	KE - 100 Closed end cap for channel No. 0 - 0205				1.6
KE.100.CE.060	KE - 100 Closed end cap for channel No. 060				1.9
KE.100.CE.080	KE - 100 Closed end cap for channel No. 080				1.0
KE.100.CE.0100	KE - 100 Closed end cap for No. 0100				1.2
KE.100.EP.0	KE - 100 end cap + pipe socket DA/OD 110 for channel No. 0				1.0
KE.100.EP.5	KE - 100 end cap + pipe socket DA/OD 110 for channel No. 5, 05				1.1
KE.100.EP.10	KE - 100 end cap + pipe socket DA/OD 110 for channel No.10, 010				1.2
KE.100.EP.20	KE - 100 end cap + pipe socket DA/OD 110 for channel No. 20, 020				1.4
KE.100.EP.80	KE - 100 end cap + pipe socket DA/OD 50 for channel No. 080				0.4
KE.100.EP.0100	KE - 100 end cap + pipe socket DA/OD 50 for channel No. 0100				0.4
KE.100.STEP	KE - 100 Step connector for compensating level differences				0.5
KE.100.OT100	Odour trap made from PVC DN 100				0.1
KE.100.OT150	Odour trap made from PVC DN 150				0.1
KE.100.OT.LEAF	Odour trap with leaf screen				0.1

Accessories available in both Galvanised Steel or Stainless Steel

KE - 100

Technical Data Sheet

KE - 100 Gratings

Slotted Steel
Grating



Perforated
Steel Grating



Mesh Steel
Grating



Composite
Slotted Grating



Composite Mesh
Grating



Composite
Oval



Ductile Iron
Slotted Grating



Ductile Iron
Longitudinal
Grating



Ductile Iron
Oval Grating



KE - 100

Technical Data Sheet

KE - 100

Gratings

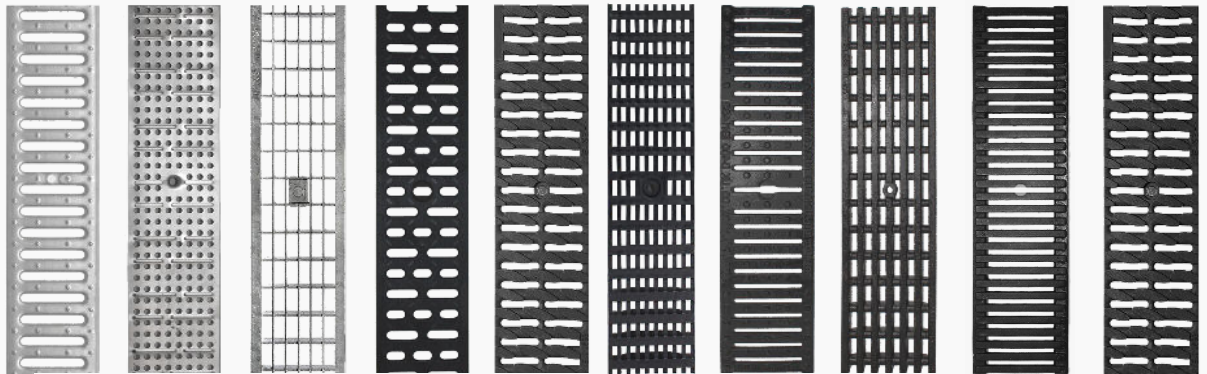

	Slotted Steel Grating	Slotted Steel Perferated Grating	Mesh Steel Grating	Composite Slotted Grating	Composite Oval Grating	Composite Mesh Grating	Ductile Iron Slotted Grating	Ductile Iron Longitudinal Grating	Ductile Iron Narrow Slotted Grating	Ductile Iron Oval Grating
A 15	•	•		•						
B 125			•			•				
C 250	•	•	•	•	•				•	•
D 400							•	•	•	•
E 600										•
Galvanised Steel	•	•	•							
Stainless Steel	•	•	•							
Ductile Iron							•	•	•	•
Composite				•	•	•				
Length (cm)	50, 100	50, 100	50, 100	50, 100	50, 100	50	50, 100	50, 100	50, 100	50, 100

Gratings cl. A15 with TwistLock fastening

Article no.	Designation	Length cm	Width cm	Inlet Ø cm ² /m	Weight kg
GR.100.SG.A	Slotted grating, galvanised, steel, SW 6 mm	100	12.3	280	2.4
GR.100.SG.A	Slotted grating, galvanised steel, SW 6 mm	50	12.3	280	1.2
GR.100.SS.A	Slotted steel grating, stainless steel, SW 6 mm	100	12.3	280	2.6
GR.100.SS.A	Slotted steel grating, stainless steel, SW 6 mm	50	12.3	280	1.4
GR.100.PG.A	Perferated grating, galvanised steel, SW 11 mm	50	12.3	719	1.9
GR.100.PS.A	Perferated grating, stainless steel, SW 11 mm	50	12.3	719	1.9
GR.100.SC.A	Slotted grating, composite SW 8 mm	50	12.3	719	1.9

KE - 100

Technical Data Sheet

KE - 100

Gratings

Gratings cl. B125 with TwistLock fastening

Article no.	Designation	Length cm	Width cm	Inlet Ø cm ² /m	Weight kg
GR.100.MG.B	Mesh grating, galvanised, MW 30 x 14 mm	100	12.3	870	3
GR.100.MG.B	Mesh grating, galvanised, MW 30 x 14 mm	50	12.3	870	1.5
GR.100.MS.B	Mesh grating, stainless steel, MW 30 x 14 mm	100	12.3	684	3.1
GR.100.MS.B	Mesh grating, stainless steel, MW 30 x 14 mm	50	12.3	684	1.5
GR.100.MC.B	Mesh grating, composite, MW 20 x 10 mm	50	12.3	684	3

Gratings cl. C250 with TwistLock fastening

Article no.	Designation	Length cm	Width cm	Inlet Ø cm ² /m	Weight kg
GR.100.SG.C	Slotted steel grating, Galvanised steel, SW10 mm	100	12.3	280	5.0
GR.100.SG.C	Slotted steel grating, Galvanised steel, SW10 mm	50	12.3	280	2.5
GR.100.SS.C	Slotted steel grating, Stainless steel, SW10 mm	100	12.3	280	5.0
GR.100.SS.C	Slotted steel grating, Stainless steel, SW10 mm	50	12.3	280	2.5
GR.100.PG.C	Perforated grating, Galvanised steel	100	12.3	178	4.6
GR.100.PG.C	Perforated grating, Galvanised steel	50	12.3	178	2.3
GR.100.PS.C	Perforated grating, Stainless steel	100	12.3	178	4.6
GR.100.PS.C	Perforated grating, Stainless steel	50	12.3	178	2.3
GR.100.MG.C	Mesh grating, Galvanised steel, MW 30 x 10 mm	100	12.3	770	4.4
GR.100.MG.C	Mesh grating, Galvanised steel, MW 30 x 10 mm	50	12.3	770	2.2
GR.100.MS.C	Mesh grating, Stainless steel, MW 20 x 14 mm	100	12.3	770	4.2
GR.100.MS.C	Mesh grating, Stainless steel, MW 20 x 14 mm	50	12.3	770	2.1
GR.100.SC.C	Slotted grating, Composite, GJL, SW 8 mm	100	12.3	350	10.4
GR.100.SC.C	Slotted grating, Composite, GJL, SW 8 mm	50	12.3	350	5.8
GR.100.OC.C	Oval Grating, Composite, SW 8 mm	100	12.3	420	2.6
GR.100.OC.C	Oval Grating, Composite, SW 8 mm	50	12.3	420	1.3
GR.100.OD.C	Oval Grating, Ductile iron, SW 8 mm	50	12.3	338	1.1

KE - 100

Technical Data Sheet

KE - 100

Gratings

Gratings cl. D400¹ with TwistLock fastening

Article no.	Designation	Length cm	Width cm	Inlet Ø cm ² /m	Weight kg
GR.100.SDI.D	Slotted Grating, Ductile Iron, Epoxy Coated 8mm Slot	50	12.3	720	2.1
GR.100.LDI.D	Longitudinal-bar grating, Ductile Iron GJL, 10 mm Slot	50	12.3	420	2
GR.100.ODI.D	Slotted narrow slotted grating, Ductile Iron GJL, 6 mm Slot	50	12.3	530	4.5

Gratings cl. E600¹ with TwistLock fastening

Article no.	Designation	Length cm	Width cm	Inlet Ø cm ² /m	Weight kg
GR.100.SDI.D	Slotted Oval grating, Ductile Iron GJL, SW 10 mm	50	12.3	420	5

Cover Gratings with TwistLock fastening - Accessories

Article no.	Designation	Length cm	Width cm	Inlet Ø cm ² /m	Weight kg
BOLT.BAR	KE - 100 TwistLock fastening, single - Composite or Galvanised				

¹ Exception: Cross-road drainage of busy roads

TwistLock fastening

The **TwistLock fastening** is used for grating types for channels with a nominal width of 100 mm.. TwistLock fastenings are optimised for the respective load class and combine safety and quality with functional design.

- Put in place – one rotation – fixed
- Assembly without special tools
- No rattling, no loosening
- No disruptive bars in the channel interior area
- Maintenance-friendly
- Resistant to corrosion



Illustration shows galvanised bar. Composite bar also used depending on grating.

KE - 100

PaveSlot

Our Paveslots are specifically designed for intergration in high quality natural stone and paving surfaces. The discrete inlet slot enables effecient drainage with access trays available for cleaning purposes.

- All Polycon Paveslots come with either an offset slot or a centre slot aswell as having the choice of a twin slot or single slot
- Available in both Glavanised Steel and Stainless Steel



KE - 100

PaveSlot

Our Paveslots are specifically designed for intergration in high quality natural stone and paving surfaces. The discrete inlet slot enables effecient drainage without compromising the ground design. We offer both single & twin slotted paveslots aswell as access trays for maintenance purposes.

Offet Single Galvanised or Stainless Steel PaveSlot

60, 105, or 150mm Upstand

A Galvanised or Stainless Steel single slot paveslot grating with a width of 123mm, available in either a 60, 105 or 150mm upstand.

Loading **C250, D400** Width **123 mm** Upstand **60, 105 or 150 mm**

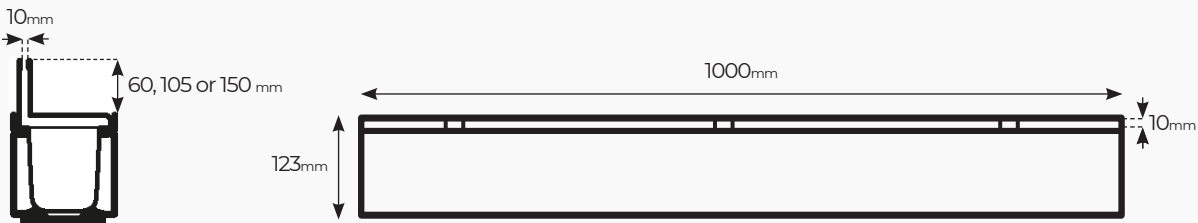

Centre Single Galvanised or Stainless Steel PaveSlot

60, 105, or 150mm Upstand

A Galvanised or Stainless Steel single slot paveslot grating with a width of 123mm, available in either a 60, 105 or 150mm upstand.

Loading **C250, D400** Width **123 mm** Upstand **60, 105 or 150 mm**

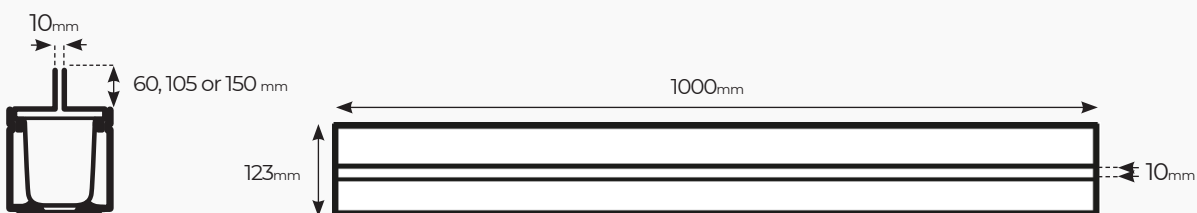

KE - 100

PaveSlot

Offset Twin Galvanised or Stainless Steel PaveSlot

60, 105, or 150mm Upstand

A Galvanised or Stainless Steel Twin slot paveslot grating with a width of 123mm, available in either a 60, 105 or 150mm upstand.

Loading C250, D400 Width 123mm Upstand 60, 105 or 150mm

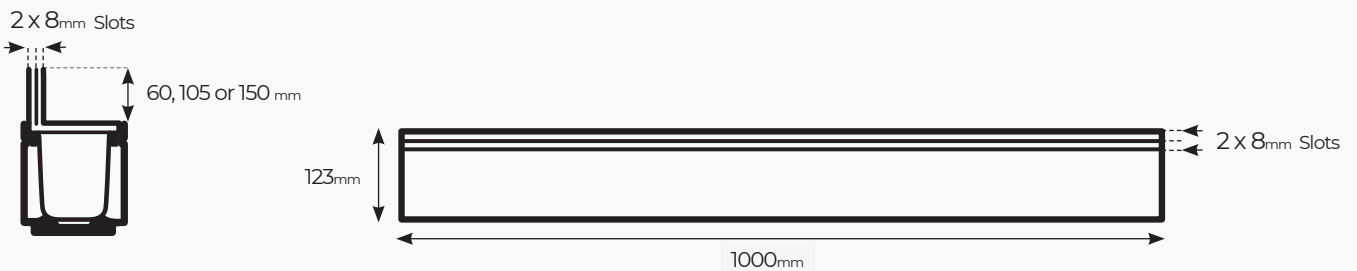
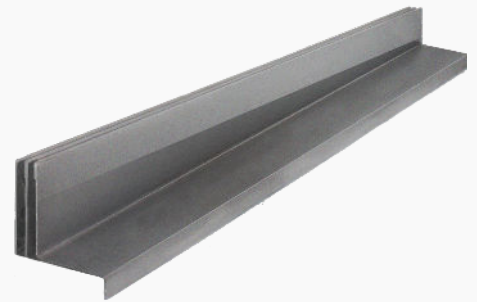

Centre Twin Galvanised or Stainless Steel PaveSlot

60, 105, or 150mm Upstand

A Galvanised or Stainless Steel Twin slot paveslot grating with a width of 123mm, available in either a 60, 105 or 150mm upstand.

Loading C250, D400 Width 123mm Upstand 60, 105 or 150mm

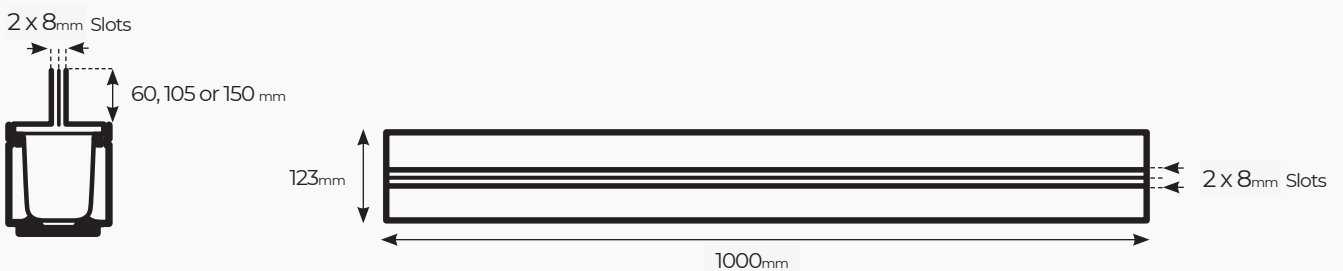

KE - 100

PaveSlot

Galvanised or Stainless Steel Access Tray

60, 105, or 150mm Upstand

A Galvanised or Stainless Steel single slot paveslot grating with a width of 123mm, available in either a 60, 105 or 150mm upstand.

Loading *C250, D400* Width *123 mm* Upstand *60, 105 or 150 mm*



Top View

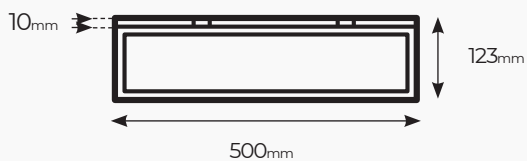

End View

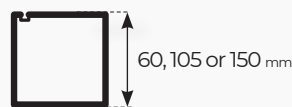

PaveSlot Specs



Offset Single PaveSlot

Article no.	Designation	Upstand Height (mm)	Overall Width (mm)	Slot Width (mm)	Length (cm)	Load Class	Weight (kg)
OS.1060.P.G	Galvanised Offset Single PaveSlot 60	60	123	10	50/100	C, D	3.7
OS.10105.P.G	Galvanised Offset Single PaveSlot 105	105	123	10	50/100	C, D	6.5
OS.10150.P.G	Galvanised Offset Single PaveSlot 150	150	123	10	50/100	C, D	9.2
OS.1060.P.SS	Stainless Steel Offset Single PaveSlot 60	60	123	10	50/100	C, D	3.4
OS.10105.P.SS	Stainless Steel Offset Single PaveSlot 105	105	123	10	50/100	C, D	6.7
OS.10150.P.SS	Stainless Steel Offset Single PaveSlot 105	150	123	10	50/100	C, D	9.4

KE - 100

PaveSlot

See the tables below for specifications on our paveslot gratings



Centre Single PaveSlot

Article no.	Designation	Upstand Height (mm)	Overall Width (mm)	Slot Width (mm)	Length (cm)	Load Class	Weight (kg)
CS.1060.P.G	Galvanised Centre Single PaveSlot 60	60	123	10	50/100	C, D	3.8
CS.10105.P.G	Galvanised Centre Single PaveSlot 105	105	123	10	50/100	C, D	6.6
CS.1050.P.G	Galvanised Centre Single PaveSlot 150	150	123	10	50/100	C, D	9.3
CS.1060.P.SS	Stainless Steel Centre Single PaveSlot 60	60	123	10	50/100	C, D	3.9
CS.10105.P.SS	Stainless Steel Centre Single PaveSlot 105	105	123	10	50/100	C, D	6.8
CS.10150.P.SS	Stainless Steel Centre Single PaveSlot 150	150	123	10	50/100	C, D	9.5



Offset Twin PaveSlot

Article no.	Designation	Upstand Height (mm)	Overall Width (mm)	Slot Width (mm)	Length (cm)	Load Class	Weight (kg)
OT.1060.P.G	Galvanised Offset Twin PaveSlot 60	60	123	2 x 8mm	50/100	C, D	7.1
OT.10105.P.G	Galvanised Offset Twin PaveSlot 105	105	123	2 x 8mm	50/100	C, D	12.5
OT.10150.P.G	Galvanised Offset Twin PaveSlot 150	150	123	2 x 8mm	50/100	C, D	17.8
OT.1060.P.SS	Stainless Steel Offset Twin PaveSlot 60	60	123	2 x 8mm	50/100	C, D	7.2
OT.10105.P.SS	Stainless Steel Offset Twin PaveSlot 105	105	123	2 x 8mm	50/100	C, D	12.7
OT.10150.P.SS	Stainless Steel Offset Twin PaveSlot 150	150	123	2 x 8mm	50/100	C, D	18.2

KE - 100

PaveSlot

See the tables below for specifications on our paveslot



Centre Twin PaveSlot

Article no.	Designation	Upstand Height (mm)	Overall Width (mm)	Slot Width (mm)	Length (cm)	Load Class	Weight (kg)
CT.1060.P.G	Galvanised Centre Twin PaveSlot 60	60	123	2 x 8mm	50/100	C, D	6.9
CT.10105.P.G	Galvanised Centre Twin PaveSlot 105	105	123	2 x 8mm	50/100	C, D	12.2
CT.10150.P.G	Galvanised Centre Twin PaveSlot 150	150	123	2 x 8mm	50/100	C, D	17.4
CT.1060.P.SS	Stainless Steel Centre Twin PaveSlot 60	60	123	2 x 8mm	50/100	C, D	7
CT.10105.P.SS	Stainless Steel Centre Twin PaveSlot 105	105	123	2 x 8mm	50/100	C, D	12.4
CT.10150.P.SS	Stainless Steel Centre Twin PaveSlot 150	150	123	2 x 8mm	50/100	C, D	17.7



Access Tray PaveSlot

Article no.	Designation	Upstand Height (mm)	Overall Width (mm)	Slot Width (mm)	Length (cm)	Load Class	Weight (kg)
AT.1060.P.G	Galvanised Offset Single Access Tray 60	60	123	10	50	C, D	3.2
AT.10105.P.G	Galvanised Offset Single Access Tray 105	105	123	10	50	C, D	6.5
AT.10150.P.G	Galvanised Offset Single Access Tray 150	150	123	10	50	C, D	9.7
AT.1060.P.SS	Stainless Steel Offset Single Access Tray 60	60	123	10	50	C, D	3.3
AT.10105.P.SS	Stainless Steel Offset Single Access Tray 105	105	123	10	50	C, D	6.7
AT.10150.P.SS	Stainless Steel Offset Single Access Tray 150	150	123	10	50	C, D	9.9

KE - 100

Technical Data Sheet



Installation Guide

Grounds conditions must be suitable and all dimensions shown are the minimum requirement. Engineering advice should be taken where necessary and any questions should be directed to Polycon's technical team through emailing us at technical@polycon.co.uk or by calling us on **0151 424 9747**

BlockPaving

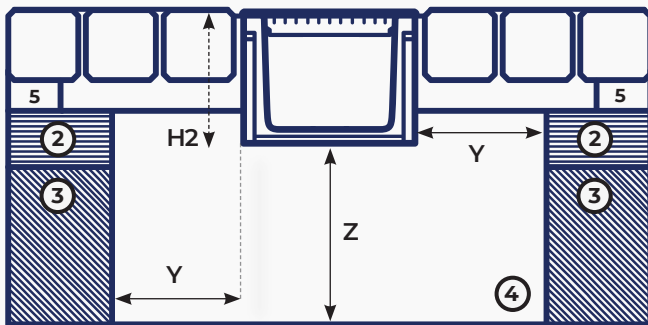

Tarmac

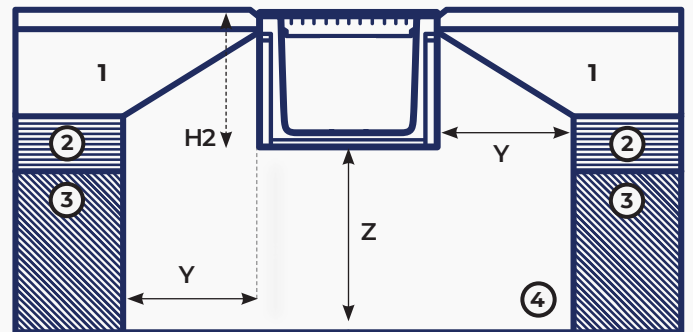

Concrete

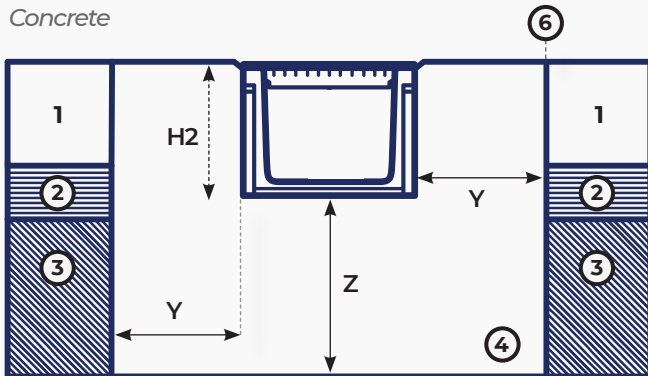

PaveSlot

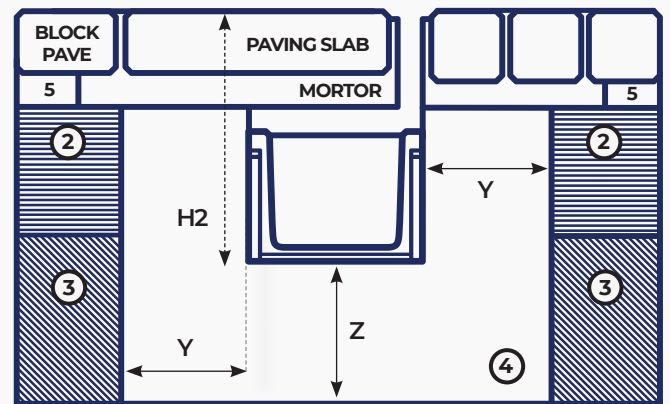

Load Class	A15	B125	C250	D400
H2 - Channel Height	Channel Height	Channel Height	Channel Height	Channel Height
Y - Minimum Surround	100mm	150mm	150mm	200mm
Z - Minimum Surround	100mm	150mm	150mm	200mm
T1 - Minimum Depth	40mm	40mm	40mm	40mm
T2 - Maximum Depth	95mm	55mm	55mm	55mm

1	2	3	4	5	6	** Minimum Concrete Haunch 25 N/mm ²
Concrete	Sub Base	Earth	Concrete Haunch	Sand Layer	Expansion Joint	Detail A Allow for overbuild of 3mm to 5mm above the grating surfaces



Polycon Surface Water Drainage

Widnes Business Park, Foundry Lane, Widnes, WA8 8UB, England

Email: info@polycon.co.uk

Tel: 0151 422 9747

Visit our website for our full range of products at www.polycon.co.uk